

US DEPARTMENT OF AGRICULTURE
SOIL CONSERVATION SERVICE

IRRIGATION DIVERSION STRUCTURE
COMMITTEE
REPORT

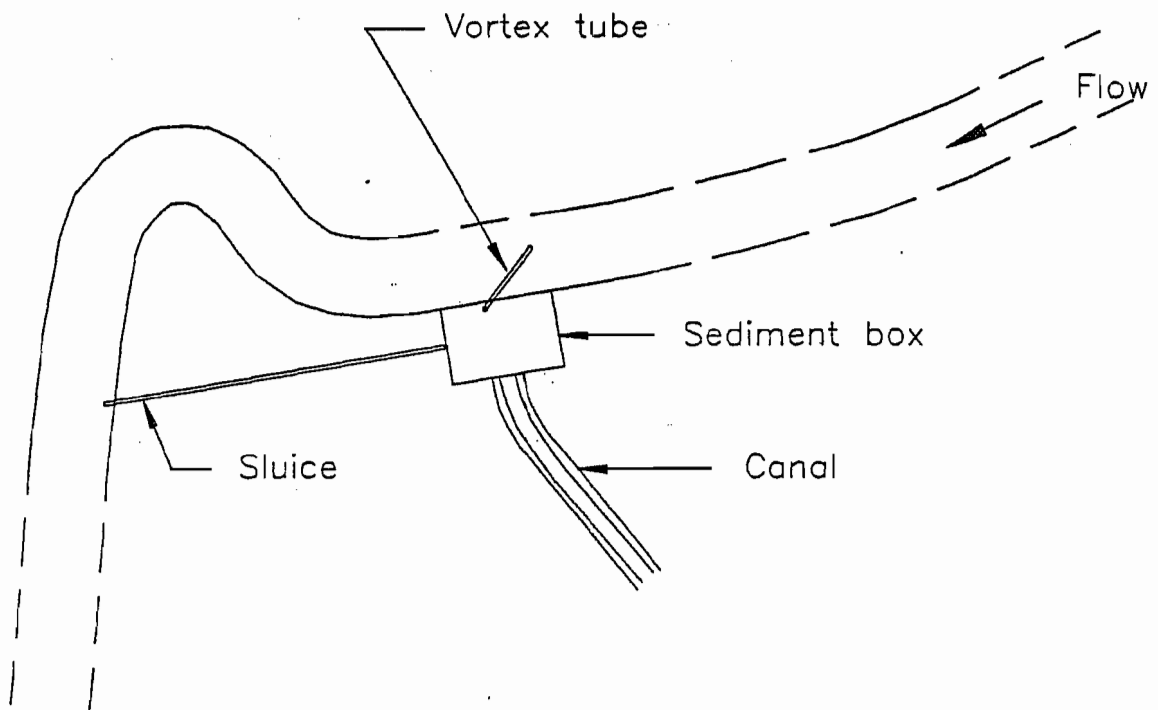

August 28, 1992

IRRIGATION DIVERSION STRUCTURE COMMITTEE
Report

31 '1

**IRRIGATION DIVERSION STRUCTURE COMMITTEE
Report**

TABLE OF CONTENTS

A.	Introduction.....	1
B.	Background.....	1
C.	Objectives.....	2
D.	Definitions.....	3
E.	Diversion Categories.....	3
F.	Stream Characteristics and Diversion Considerations.....	3
G.	Types of Diversion Structures.....	4
H.	Service Life.....	5
I.	Low Initial Cost Irrigation Diversion Structure Concepts.....	5
J.	Check devices.....	5
K.	Conclusions.....	6
L.	Recommendations.....	7
M.	Acknowledgements.....	8
 Appendix I - Tables.		
	Table 1- Diversion Categories - Head vs Diversion Material.....	I-1
	Table 2 - Diversion Structures Material by Life.....	I-2
 Appendix II - Concepts.		
	Infiltration Gallery.....	II-1
	Vortex Tube Gallery.....	II-9
	Steel Plate.....	II-16
	Mass Foundation and Check.....	II-21
	Pile/Post Foundation and Check.....	II-31
	Pump.....	II-38
 Appendix III - Checks.		
	Jack and Stoplog/Timber Check.....	III-1
	Inflatable Fabric Check.....	III-3
	Log Check.....	III-5
	Lift Panel Check.....	III-7
	Prefabricated Beam Check.....	III-9
	Swinging Pipe Check.....	III-11
	Wire Fencing and Geosynthetic Check.....	III-13

IRRIGATION DIVERSION STRUCTURE COMMITTEE

Report

July 17, 1992

A. Introduction.

Many irrigation diversion structures in the western states were established in the late 1800s and early 1900s. These sites may have been established with permanent structural works across the stream or consisted of a canal or ditch intersecting the stream channel. Many of the diversion sites are located on rivers or streams that have had degradation of the channel bottom. With the channel degradation and resulting lowering of the water level in the stream, the desired irrigation flow can no longer be diverted. To compensate for this loss of head some Irrigation Districts (Companies) and/or individual owners have entered the rivers or streams annually to build, extend or repair gravel diversions in order to direct and raise the water to their intake structures. In most cases this work has been done without permits, such as the 404 permit, being obtained. Some states have instigated or are instigating legislation to prohibit this practice. As the building of gravel diversions is prohibited these owners will be required to install other measures to divert and/or raise water levels. Also the construction of permanent headwalls with large drops across a stream is not always the desired solution. Recreational considerations such as canoeing and rafting, and fish migration need to be evaluated.

Current SCS criteria and practices often dictate that new structures will be costly. There is a need in the SCS to develop low cost alternative structures accepting higher maintenance in place of high initial cost. The Irrigation Diversion Structure Committee was formed to identify possible alternative structure types.

B. Background.

Discussions were held between Richard Gooby, State Conservationist, Montana, and William Evans, Head, Engineering Staff, WNTC in January 1990 and a committee formed to investigate the problem. The committee members were confirmed March 29, 1990 and informed of a pending meeting in the summer of 1990. The committee members were as follows:

Lewis L. Burton, Design Engineer, SCS, Bozeman, Montana
Paul J. Monville, Civil Engineer, SCS, WNTC, Portland, Oregon
Keith M. Robertson, District Conservationist, SCS, Hamilton, Montana
Elwin A. Ross, Irrigation Engineer, SCS, WNTC, Portland, Oregon

G. Arthur Shoemaker, State Conservation Engineer, SCS,
Salt Lake, Utah
Charles K. Taylor, Area Engineer, SCS, Worland Wyoming

The committee's first meeting was held in Missoula, Montana during the week of July 23, 1990 with Elwin Ross as chairman. The committee, representatives from other state and federal agencies, and local cooperators toured irrigation diversion structures in the Missoula, Hamilton, and Dillon areas and met in a controlled brainstorming discussion. As a result of the tour and discussion an objective and two action items were identified. The objectives and action items are described in Section C. Objectives.

The committee met in Portland, Oregon January 15 through 17, 1991 chaired by Elwin Ross. Also present were Dr. John Replogle of the Agricultural Research Service in Phoenix, Arizona, and Jack Haynes of the Bureau of Reclamation in Denver, Colorado. Bruce Wilson, Assistant State Conservation Engineer of the SCS in Portland, Oregon joined the discussions.

The committee was presented with a copy of a catalog of structures (Action Item I) for their review and agreed to submit comments by March 1, 1991.

The committee reviewed and discussed the responses for ideas for diversion structures and identified 11 concepts for further development. These concepts were assigned to committee members and would be reviewed at the next committee meeting in the summer.

A third committee meeting was held in Jackson Hole, Wyoming August 27 through 29, 1991. Paul Monville replaced Elwin Ross as chairman. In addition to Dr. Replogle and Jack Haynes, Al Wipperman of the State of Montana, Department of Fish, Wildlife, and Parks was present.

The assigned concepts were reviewed by the committee and comments given to the authors for resolution. The original 11 concepts were consolidated to 6. Seven check types were identified and assigned to committee members for development. The structure concepts and checks are included in this report.

C. Objectives.

The committee objective was defined as providing an irrigation diversion that meets the needs or desires of diverse individuals or groups concerned with natural streams.

In order to help the committee accomplish their objective two action items were defined as follows:

1. Action Item I. Collect and consolidate examples of all irrigation diversions from the western states. This would include both existing "standard" structures and "designed" structures.
2. Action Item II. Identify new and innovative ideas/concepts/criteria for "low cost" environmentally sound irrigation diversions.

To satisfy action item I the committee solicited drawings for irrigation diversion structures from the west states; prepared a catalog of these drawings, entitled West States Irrigation Diversion Structure Catalog; and distributed the catalog to the western states by West NTC Bulletin No. W210-1-15 dated April 30, 1991.

To satisfy action item II the committee solicited responses from the SCS and other federal and state agencies for ideas on new and innovative low cost structures; discussed these ideas in the subsequent meetings; and developed concepts to meet the objectives. These concepts are anticipated to be used by the states to develop standards. The development of the concepts is described in the remainder of the report.

D. Definitions.

Check. A permanent or temporary irrigation diversion dam.

Foundation. A base in the streambed to which a check is attached.

Gallery. A water collection system constructed beneath the stream invert.

Head. The depth of water at the diversion available for delivering the required irrigation flow to the system.

Horizontal gallery. A gallery that extends horizontally across the streambed.

Inflatable fabric. An enclosed material which when filled with water will act as a check.

Jacks. A series of braced supports for flashboard checks.

Lift panels. Also called an overshot gate. A fabricated panel hinged at the upstream end at the canal invert and raised or lowered with a cable fastened at the downstream end.

Low cost. Low initial construction/installation cost.

Non-obstructive diversion. A structure that is capable of diverting irrigation flow without impeding the flow in the stream.

Obstructive diversion. A structure that will impede the stream flow in order to divert for irrigation purposes.

Permanent check. A check that cannot easily be removed or lowered.

Pipe gallery. A water collection system beneath the streambed generally composed of perforated conduit embedded in a rock or gravel envelope.

Temporary check. A check structure that can be easily removed or lowered.

Vertical gallery. An infiltration gallery that extends vertically to the streambed.

Vortex tube. A slotted conduit across the streambed that transports water and sediment with a spiral action.

E. Diversion Categories.

Irrigation diversion structures can be divided into four categories of head as follows:

- a. 0 to 3 feet
- b. 3 to 6 feet.
- c. 6 to 10 feet.
- d. Greater than 10 feet

Types of materials to construct diversions in the four categories are given in Table 1 - Diversion Categories - Head vs. Diversion Materials in Appendix I - Tables.

As the head increases the complexity of the structure also increases. It is concluded that the 0 to 3 feet category most likely contains the low initial cost structures and is consistent with the objective. These structures generally require high maintenance.

F. Stream Characteristics and Diversion Considerations.

An understanding of stream characteristics is necessary to evaluate diversion alternatives. Stream characteristics considered include bed material, slope, fish movement, bed/bank stability, recreation use, seasonal flow, and peak flows. Diversion considerations include discharge, period of operation, water quality, and stream user needs.

G. Types of Diversion Structures.

For purposes of this report irrigation diversions are classified as non-obstructive or obstructive. Galleries and pumps are considered non-obstructive types. Dams or checks are considered obstructive types. The obstructive types are further subdivided into temporary, permanent or a combination of each type.

In non-obstructive structures discharge is the major design consideration rather than the available head. Gallery structures may be horizontal or vertical. Horizontal galleries may be constructed of pipe, timber cribbing, french drain, or geotextile fabric. Vertical galleries may be

constructed of pipe, steel sheet pile, and timber cribbing or piling.

Temporary obstructive structures have checks that may be removed from the stream cross section when not diverting for irrigation. These structures consist of a foundation or base and a removable check such as jacks with stoplogs. The foundation may be constructed of steel plate, concrete, loose rock, timber, pipe, grouted rock, gabion, steel piling or posts, and timber piling or posts.

Permanent obstructive structures are dams that will remain in place. These structures may be constructed of the same material as used for the temporary obstructive structures.

Combinations of permanent and temporary obstructive structures may be used in a single diversion structure.

H. Service Life

Service Life, as defined in some SCS practices, is classified as short, medium and long. For purposes of classifying diversion structures the following period of time is assigned to each.

0 to 5 years	Short life
5 to 20 years	Medium life
Greater than 20 years	Long life

A list of structures constructed of various materials and classified by type and service life was developed and is given in Table 2 - Diversion Structures - Material by Life. Examination of the table leads to the conclusion that a low cost diversion structure generally has a life of 5 to 20 years, or even may be reinstalled annually.

I. Low Initial Cost Irrigation Diversion Structure Concepts.

As developed in the previous sections the typical range of head for low cost diversion structures is 0 to 3 feet. The structures in this range of head are generally rated as short to medium life structures.

Based on the above criteria the following concepts have been developed.

1. Infiltration Gallery
2. Vortex Tube Gallery
3. Steel Plate
4. Mass Foundation and Check

5. Pile/Post Foundation and Check
6. Pump Plant

The description of the structure concepts, including sketches, planning considerations, and design criteria and specifications are given in Appendix II - Concepts.

J. Check devices.

Check devices are generally used with temporary obstructive type diversions with a permanent foundation. These checks include the following types:

1. Jack and stoplog/timber check
2. Inflatable fabric check
3. Log check
4. Lift panel check
5. Prefabricated beam check
6. Swinging pipe check
7. Wire fencing and geosynthetic check

Design criteria and specifications are given for each of the above checks in Appendix III - Checks.

K. Conclusions.

Based on the meetings and development of the structures the committee has made the following conclusions:

1. Interaction with outside agencies and interests is very productive.
2. The Irrigation Diversion Structure catalog will fill a need in the SCS.
3. Low cost irrigation structures can be defined and specific types can be developed.
4. The committee recognizes that there may be other feasible concepts for low cost diversion structures rather than those developed.

As a result of interaction with representatives from other state and federal agencies, and local cooperators in the Missoula, Hamilton, and Dillon areas the committee was able to establish objectives that met the diverse concerns of the varied groups. The participation of Dr. John Replogle and

Jack Haynes in the Portland and Jackson meetings provided technical input that assisted the committee in the development of the concepts presented. Al Wiperman provided environmental balance to the committee's efforts in the Jackson meeting.

The response from recipients of the Irrigation Diversion Structure catalog is that it will be helpful in the selection and design of diversion structures. This response leads to the conclusion that the preparation of the catalog was timely and worth while.

The committee's greatest effort was concentrated on defining and developing specific types of low cost environmentally sound irrigation diversion structures through the identification of their characteristics as follows:

1. The typical range of available head is 0 to 3 feet, except for non-obstructive structures where discharge is the major design consideration rather than the available head.
2. Generally the life is 5 to 20 years, or it may be reinstalled annually. These are rated as short to medium life structures.
3. The structures are usually the non-obstructive or temporarily obstructive type. Obstructive type diversions are generally not environmentally acceptable and other types should be investigated when possible.
4. Six types of irrigation diversion structures were selected as meeting the requirements of low cost and environmentally sound.
5. Seven check devices were selected to be used with foundations of temporary obstructive diversions.

Descriptions including sketches, planning considerations, and design criteria and specifications have been developed for each of the six types of diversion structures. This information is given in Appendix II - Concepts.

Design criteria and specifications for each of the seven check devices have been developed and included in Appendix III - Checks. Also included are descriptions, sketches, references, and costs.

Two other types of structures were discussed during the meetings and considered usable where applicable. These structures were the Reichmuth Diversion and a thin plain concrete hard section. The Reichmuth Diversion is a rock gradient control using large rock in a "v" formation in plan with the closed end of the "v" facing upstream. This type of

structure is similar to the mass foundation using rock and was not introduced as a separate type of structure. The thin plain concrete hard section is similar to the mass foundation using plain concrete and could be used in it's place .

L. Recommendations.

The following recommendations are a product of the committee's discussions and conclusions:

1. The structure and check information given in Appendix II and III should be distributed to the western states and to other interested parties outside of the SCS.
2. The states should be advised that the information provided may be used to develop state standards.
3. The users should be made aware of potential for degradation and aggradation of the stream when disturbed by the construction and operation of diversions.
4. A search should be continued for other solutions to the problem of irrigation diversion structures, i.e.. development of sketches and criteria for the Reichmuth diversion and thin plain concrete sections.
5. A periodic update of the Irrigation Diversion Structure Catalog should be made.
6. Revision of National Standards for temperature steel requirements for short life reinforced concrete non-structural slabs should be considered.
7. Revision of SCS standards should be considered to include both thick and thin plain concrete sections in high maintenance irrigation diversion structures.

M. Acknowledgements.

The committee commends the following persons for their contributions to the concepts presented:

Jack A. Haynes, Civil Engineering Technician, USDI, Bureau of Reclamation, Denver Colorado

Dan Merkel, Environmental Protection Agency, Denver, Colorado

John Peters, Environmental Protection Agency, Denver Colorado

John Repogle, Research Hydraulic Engineer, Agricultural Research Service, Phoenix, Arizona

D. James Suit, State Conservation Engineer, Soil Conservation Service, Bozeman, Montana

Al Wipperman, State of Montana, Department of Fish, Wildlife,
and Parks, Helena, Montana

Bruce Wilson, Assistant State Conservation Engineer, Soil
Conservation Service, Portland, Oregon

Lowell Kenedy, State Design Engineer, Soil Conservation
Service, Salt Lake City, Utah

Paul J. Monville

Paul J. Monville, chairman

7-17-92

date

Lewis L. Burton

Lewis L. Burton, member

7/29/92

date

Keith M. Robertson

Keith M. Robertson, member

8-10-92

date

Elwin A. Ross

Elwin A. Ross, member

7-17-92

date

G. Arthur Shoemaker

G. Arthur Shoemaker, member

8/17/92

date

Charles K. Taylor

Charles K. Taylor, member

8/20/92

date

Appendix I
Tables

DIVERSION CATEGORIES
Head vs. Diversion Material
Table 1

		Head		
0 TO 3 Feet	3 to 6 Feet	6 to 10 Feet	>10 Feet	
Pipe	Timber	Gabion/Concrete	Concrete	
Loose Rock	Grouted Rock	Steel	RCC	
Logs and Timber	Gabion/Rock	Concrete	Pumps	
Fabric	Loose Rock	RCC	Dams	
Gabion	Steel	Pumps	Sheet Pile	
Steel - prefab	Concrete Masonry			
Conc/masonry /block	Concrete			
Sack Crete	Sack Crete			
Earth	Pumps			
Misc. - Wire /Rock etc.				

DIVERSION STRUCTURES
Material by Life
Table 2

1. Non-obstructive.
 - a. Short Life - no back flush

(1) French Drain	(3)	Loose Rock Control Section
(2) Fabric		
	(4)	PVC Tubing
 - b. Medium Life

(1) Steel Pipe (Horizontal and Vertical)	(3)	Sheet Pile
	(4)	Control Section
(2) Timber Crib (Horizontal and Vertical)		Grouted Rock Timber Steel
 - c. Long Life

(1) Concrete Pipe	(3)	RC Control Section
(2) RC Box	(4)	Sheet Pile
2. Temporary Obstructive (Seasonal)*
 - a. Short Life

(1) Gravel/Rock Dike	(3)	Sack Crete
(2) Steel Plate Sill**		
 - b. Medium Life

(1) Steel Plate Sill**	(5)	Sheet Pile**
(2) Timber Crib**	(6)	Gabion**
(3) Pipe Sill**	(7)	Mass Concrete**
(4) Grouted Rock**	(8)	Inflatable Dam
 - c. Long Life

(1) Reinforced Concrete**	(2)	Sheet Pile**
---------------------------	-----	--------------
3. Permanent Obstructive
 - a. Short Life

(1) Concrete Block/Rock and Mortar	(3)	Fence/Fabric
(2) Log Sill	(4)	Gravel/Rock
 - b. Medium Life

(1) Timber Crib	(4)	Masonry
(2) Gabion	(5)	Rock Dike
(3) Log Crib		
 - c. Long Life

(1) Reinforced Concrete	(3)	Roller Compacted Concrete
(2) Sheet Pile		

* Streambed level with structure floor

** Dismountable flashboards

Appendix II
Concepts

IRRIGATION DIVERSION STRUCTURE INFILTRATION GALLERY

The infiltration gallery is adaptable to a wide range of conditions, however they will be most applicable in relatively stable stream channels where the diverted flow is less than 15 cfs. Systems have been designed for much larger flows than this, however they would likely become complex and costly. They are probably best adapted to streams with coarse bed materials such as sand, gravel or cobbles.

They would be especially useful in situations where intermittent flow combined with storage capability existed. They would also be well adapted to pump or gravity pipe distribution systems.

This concept generally consists of installing a perforated pipe and gravel drain collection system in the bottom of a stream channel to collect and divert irrigation water into an adjacent canal or pipeline. The concept would generally use horizontal pipe networks in the stream bottom, however alternative systems may include gravel drain collection systems, vertical pipe collectors, sheet pile, geotextile, or other collection systems. See figures 1 through 4 for alternative details. Generally it would be best adapted to stable sites. Significant aggradation or degradation at the site could result in a system failure.

With this type of system sediment is filtered out of the water, resulting in diversion of relatively sediment free water. Sediment remains in the stream channel.

Generally this type of diversion will require backflush capability. Backflushing is accomplished by creating reverse pressure and flow through the collection and filtering system in order to clean out accumulated sediment. This would usually be done by pumping.

IRRIGATION DIVERSION STRUCTURE
PLANNING AND DESIGN CONSIDERATIONS
INFILTRATION GALLERY

1. Streambed Material
 - a. These systems can be used in all materials but will require less maintenance and may be less costly in coarse bed load streams (sand, gravel, cobble). Fine grained soils will require greater maintenance probably requiring more backflushing.
 - b. Streambed material will affect sizing of the gravel filter zone and the pipe size.
2. Pipe Material
 - a. Well Screen
 - b. PVC Perforated Pipe
 - c. Corrugated P.E. Perforated Pipe
 - d. Other Available Pipe Materials
3. Other Materials - The concept of collecting water in the stream channel and diverting it to an irrigation system may be accomplished with material other than pipe. Some possible alternative include:
 - a. Sheet Piles - Steel sheet piling placed in two rows could serve as a collector and conduit to divert water.
 - b. Geotextile Drains - Geotextile drain materials used in conjunction with an impermeable barrier could serve as a collection system.
 - c. Gravel French Drain - Gravel collector system with no pipes or other diversion facilities other than the gravel. Would probably be limited to small flows.
4. Backflush needs will generally require low head pumping capability.
5. May require filter fabrics or other filtering medium around gravel pack.
6. Sizing of the system is related to available head and capacity requirements
7. Size and layout of the system is dependent on stream size and configuration.
8. This type of system leaves most sediment in the stream.
9. It is felt that this type of system is most applicable for diverted flows between 1 and 15 cfs, however these systems can be adapted to larger flows.

10. Cost of the system will vary considerably based on site conditions and type of collection system, size of conduit required, availability of gravel, back flush needs, etc.
11. Life - The materials used should be compatible with the life expectancy of the system. Adequate back flush and maintenance practices would need to be followed or the life could be significantly reduced. With proper design and maintenance infiltration galleries can be long life systems.

**IRRIGATION DIVERSION STRUCTURE
DESIGN CRITERIA AND SPECIFICATIONS
INFILTRATION GALLERY**

The SCS does not have any specific design criteria or specifications for infiltration galleries. SCS designs and criteria are available for design of specific elements of the system such as pipes or filters. These include:

1. Soil Conservation Service, NEH Section 5 Hydraulics, Soil Conservation Service, Washington D.C.
2. Soil Conservation Service, SM-1 Guide for Determining the Gradation of Sand and Gravel Filters, Soil Conservation Service, Washington D.C.
3. Soil Conservation Service, Engineering Design Standards - Far West States, West National Technical Center, Portland, Oregon, 1970.
4. Soil Conservation Service, NEH-20 Specification 24, Drainfill; 203, Geotextiles; and 207, Plastic Pipe, Soil Conservation Service, Washington D.C.

One good source for criteria and design of complete infiltration galleries is an article in the Johnson Drillers Journal, Third Quarter, 1981 titled "Large Quantities of Water Can be Drawn Through Infiltration Galleries," by Robert E. Buss.

IRRIGATION DIVERSION STRUCTURE INFILTRATION GALLERY

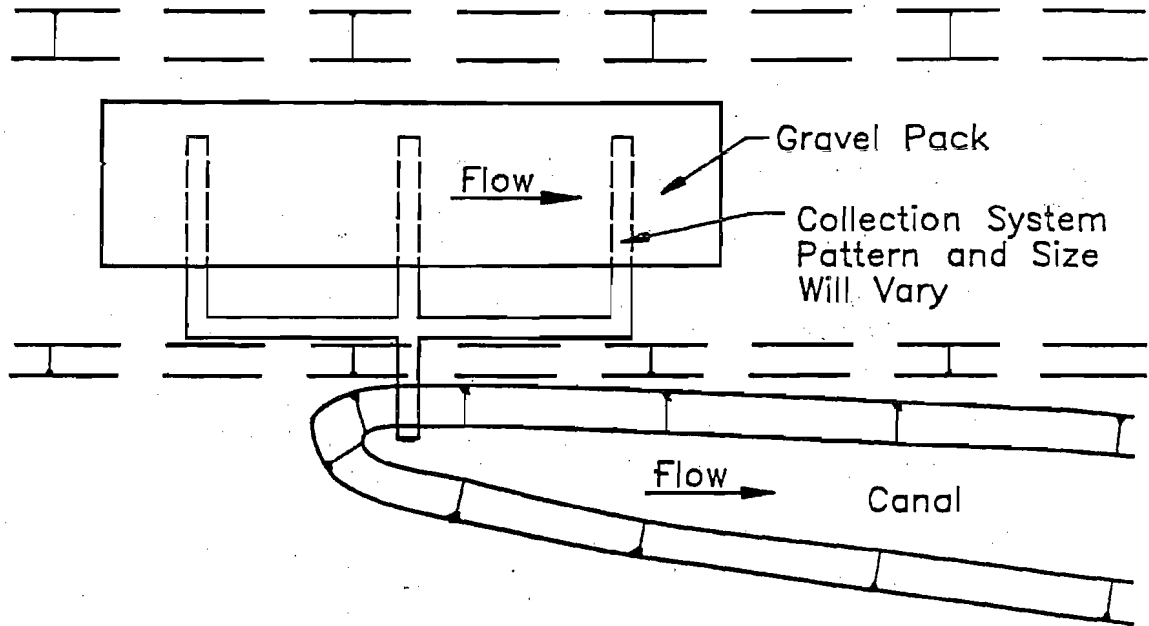

PLAN

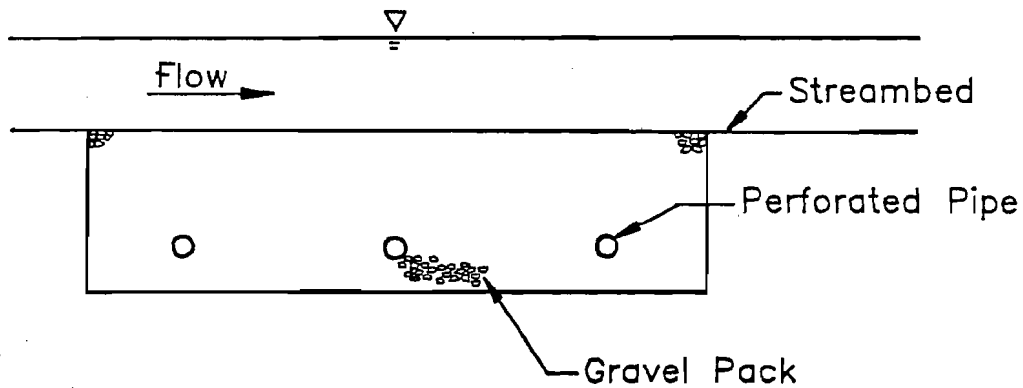

PROFILE

TYPICAL LAYOUT

FIGURE 1

IRRIGATION DIVERSION STRUCTURE INFILTRATION GALLERY

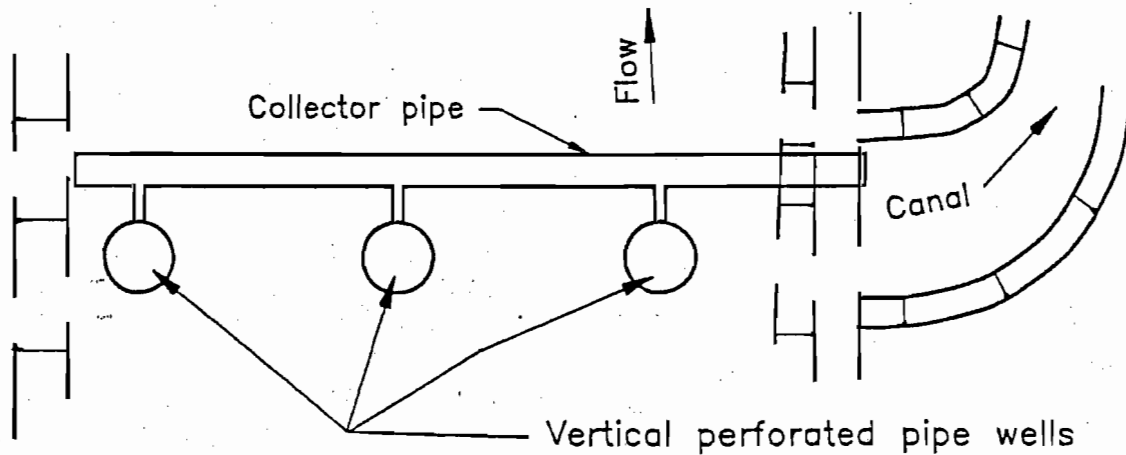

PLAN

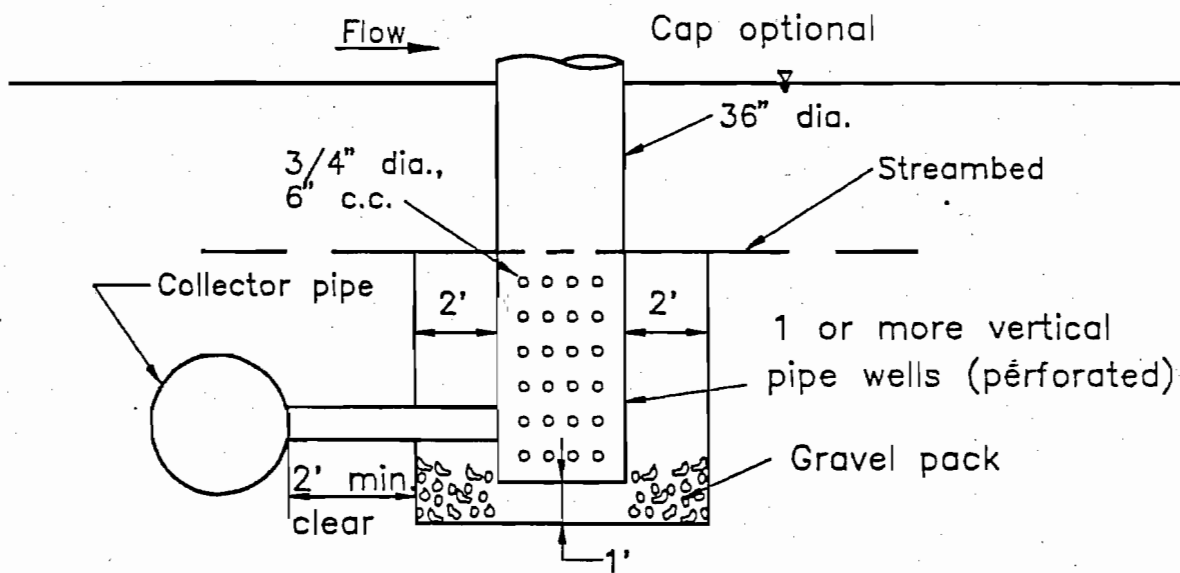

PROFILE

VERTICAL WELLS

FIGURE 2

IRRIGATION DIVERSION STRUCTURE INFILTRATION GALLERY

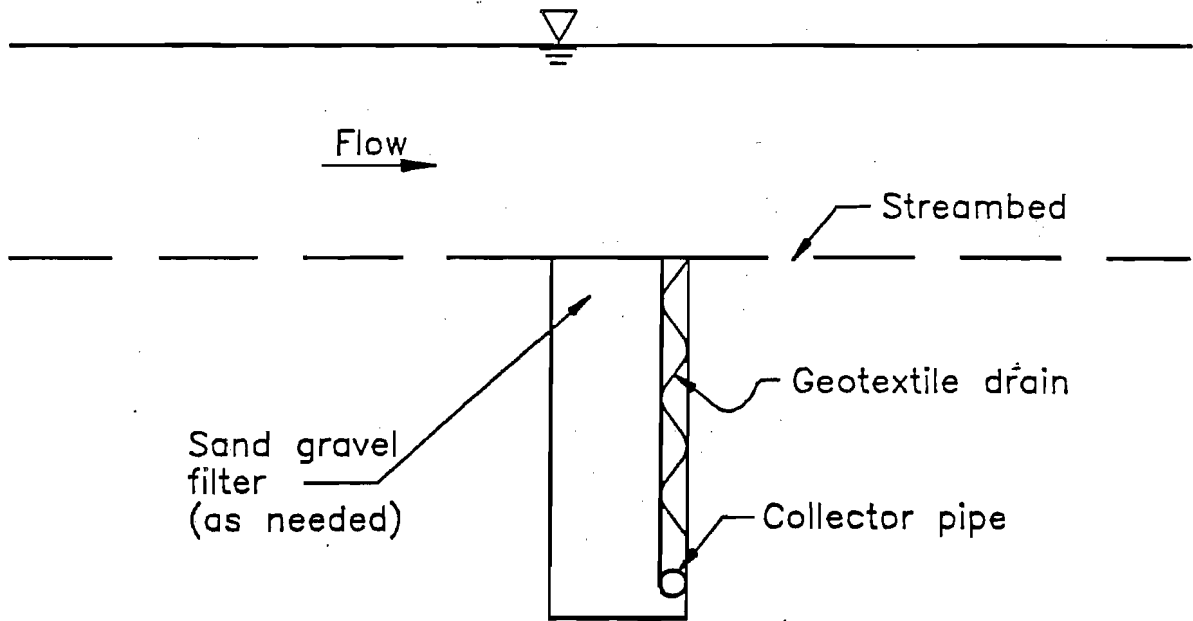
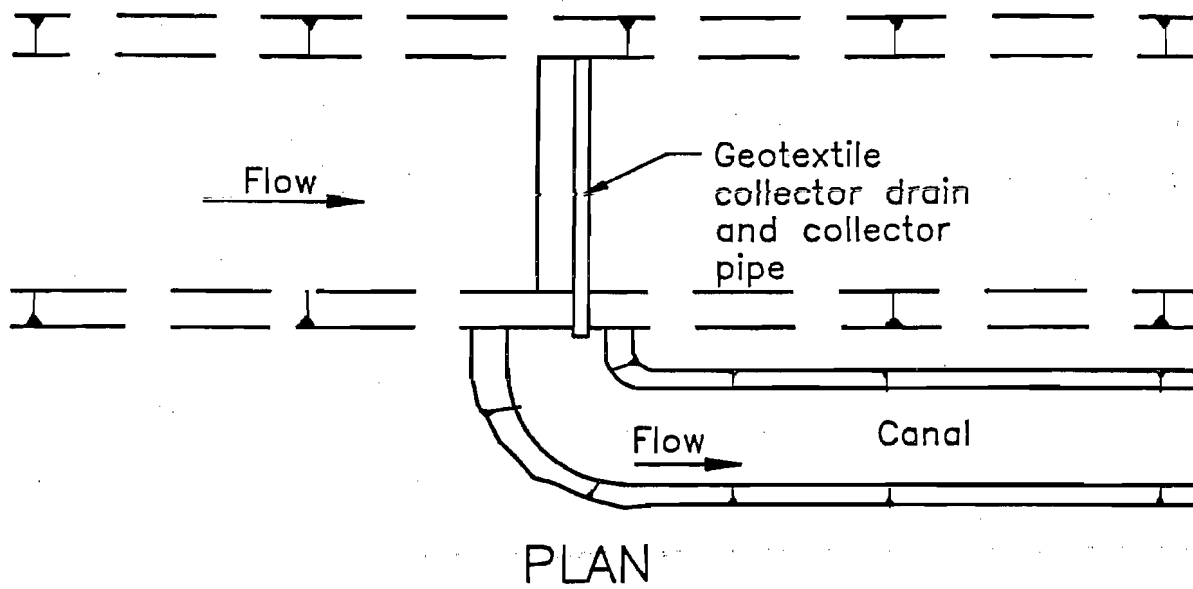

PROFILE
GEOTEXTILE COLLECTOR

FIGURE 3

IRRIGATION DIVERSION STRUCTURE INFILTRATION GALLERY

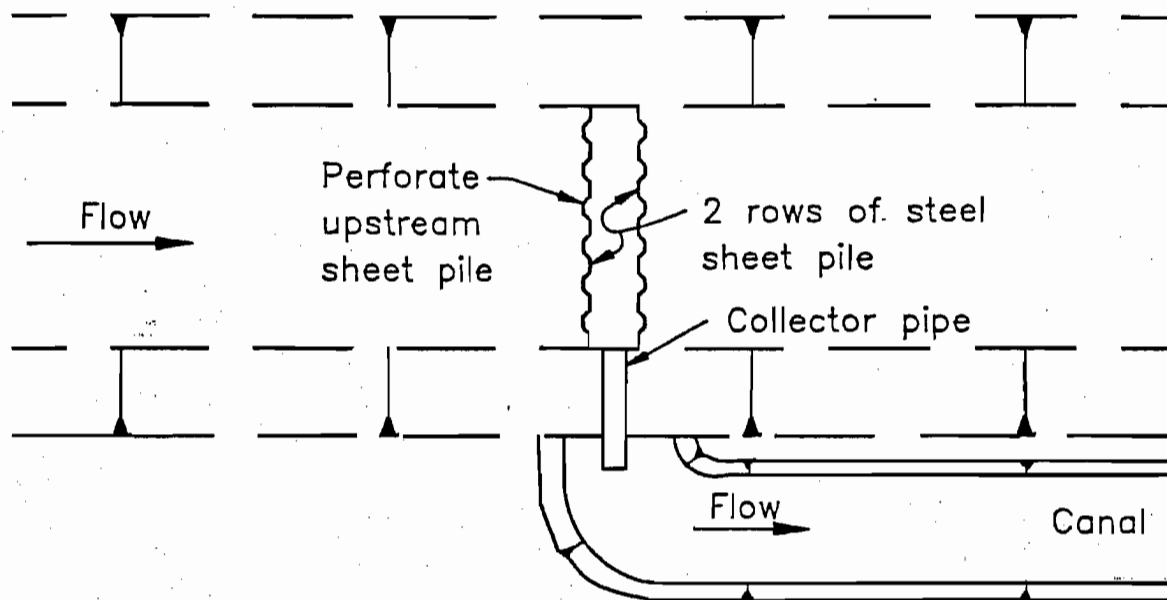

PLAN

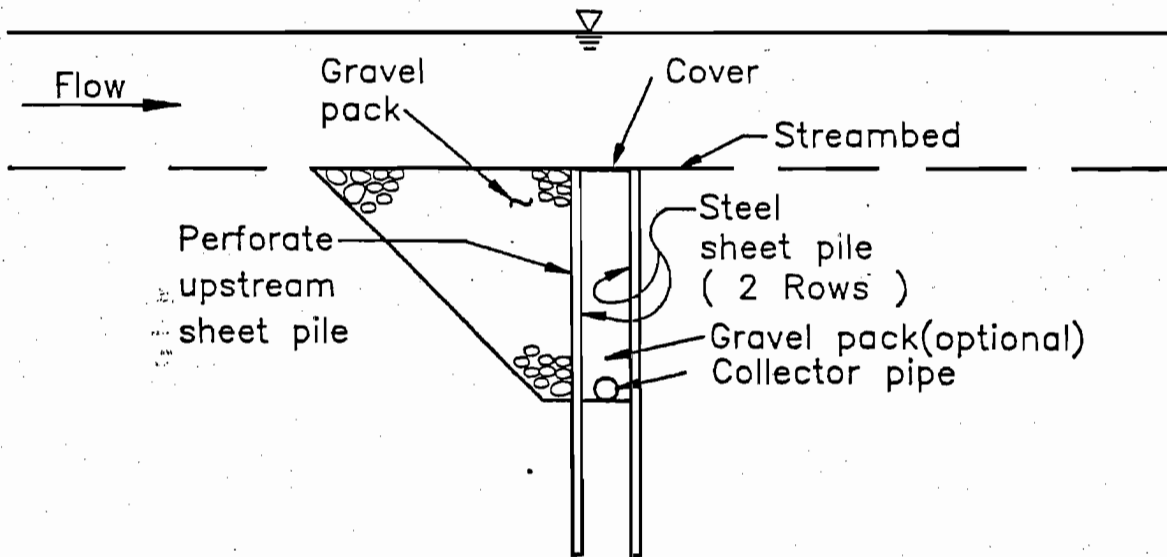

PROFILE

SHEET PILE COLLECTOR

FIGURE 4

IRRIGATION DIVERSION STRUCTURE VORTEX TUBE GALLERY

This concept consists of using a slotted conduit (open top) as a vortex tube gallery for the diversion of stream flow. It is suited for use in narrow, relatively deep streams where most of the flow is required to be diverted at low flows and obstructions in the stream are undesirable. The conduit would be placed in the stream bottom and would divert water and sediment to a box for separation. The sediment would be returned to the stream or otherwise be disposed of when it reduces the quality of the water beyond the acceptable limits. The slotted conduit could be steel, concrete, or plastic pipe. The box could be timber, concrete, or earth. The return could be a pipe or a channel. A typical site plan is shown in figure 1. Figure 2 is a typical stream plan and profile showing the vortex tube. Alternate details of the slotted conduit are given in Figure 3.

VORTEX TUBE

The vortex tube is a sediment removal device. To be used for diversion of water for irrigation it will be required to move the accompanying sediment without plugging. In order to move the sediment it will be necessary to design the tube for sediment removal and check the size for the capacity to provide the irrigation water required. An estimate of the sediment particle size and the sediment and water proportions must be made. Hydraulics of the tube should be run for stream flow at maximum sediment stage and at minimum water stage during the irrigation season. A gate is needed at the end of the tube to control the flow.

SEDIMENTATION BOX

The sedimentation box will receive the sediment and water and divert the water to the irrigation facility. The size of the box is dependent upon the amount of sediment anticipated and upon the amount of maintenance expected to be performed for sediment removal.

SEDIMENT DISPOSAL

Sediment disposal may be performed by removal or flushing. Removal can be either by hand or equipment.

IRRIGATION DIVERSION STRUCTURE
PLANNING AND DESIGN CONSIDERATIONS
VORTEX TUBE GALLERY

1. Streambank Material
 - a. It would appear that the stream bank materials could be any type of material.
2. Streambed shape
 - a. Average gradient in the area of the site should be that required to support subcritical flows. However, the drop should be sufficient to permit the return of sediment to the stream if this is the method of disposal.
 - b. A narrow, relatively deep section is preferred to a wide, shallow section, particularly if all flow is required at low stream discharges.
3. Stream channel sediment
 - a. Bedload
 - (1) The sand and gravel bedload will be introduced into the vortex tube.
 - b. Suspended sediment
 - (1) No experience has been found that shows that this type of intake device has the potential for clearing a once plugged tube
 - (2) If suspended sediment is received it will have to be determined if settling is necessary or if the water may be used as is.
4. Trash and debris
 - a. Trash and debris may be a problem. Trash diversions upstream or frequent maintenance may be necessary.
5. Diversion discharge requirements
 - a. The maximum discharge is expected to be about 10 cfs for a 12 inch diameter pipe.
6. Sediment handling
 - a. Sediment taken with the water will have to be trapped, and sluiced or removed.
7. Head requirements
 - a. The irrigation flow takeout water surface will have to be at an elevation below the vortex tube invert for maximum efficiency.
8. Materials availability
 - a. Corrugated metal pipe appears to be the most appropriate material since the slots can be cut at reasonable lengths leaving sections of undisturbed pipe for strength. Any type of pipe, particularly plastic pipe can be used as a form for cast in place concrete vortex section.

- b. Wood, concrete, or earth may be used for the construction of the sedimentation box. Wood and concrete permits a shorter more efficient length of vortex tube than for an earth embankment.

9. Costs

- a. The cost of material and installation of the vortex tube pipe should be about \$200 to \$400 for a 12 inch diameter pipe with concrete encasement. Since installation could generally be done with available tools and equipment this cost does not include overhead and profit.
- b. Sedimentation box. If wood is available the costs of the material and installation of the sedimentation box should be about \$500 to \$1000, where the lesser cost is for a stream with coarse sediment and the greater cost for a stream with finer sediment.
- c. If low cost labor and appropriate equipment is available manual removal of sediment may be the least cost method of sedimentation removal. The cost of providing a sluice will increase with the length of sluice required.

IRRIGATION DIVERSION STRUCTURE
DESIGN CRITERIA AND SPECIFICATIONS
VORTEX TUBE GALLERY

Design Criteria.

References:

1. Klingeman Peter C., Milhous Robert T., Oak Creek Vortex Bed-Load Sampler, Oregon State University, Corvallis, Oregon, 1970.
2. Mahmood Khalid, Flow Through Vortex Tube Sediment Ejectors, ASCE Irrigation and Drainage Division Specialty Conference, Logan Utah, August 13-15, 1975.
3. Melone A.M., Richardson E.V., Simons D.B., Exclusion and Ejection of Sediment from Canals, Department of Civil Engineering, Colorado State University. Fort Collins, Colorado, April 1975.
4. Robertson A.R., Vortex Tube Sand Trap, Transaction ASCE Vol. 127, Pt. III, 1962.

Specifications:

1. National Handbook of Conservation Practices, Dam, Diversion 348, Soil Conservation Service, Washington D.C., Oct. 1977.

IRRIGATION DIVERSION STRUCTURE VORTEX TUBE GALLERY

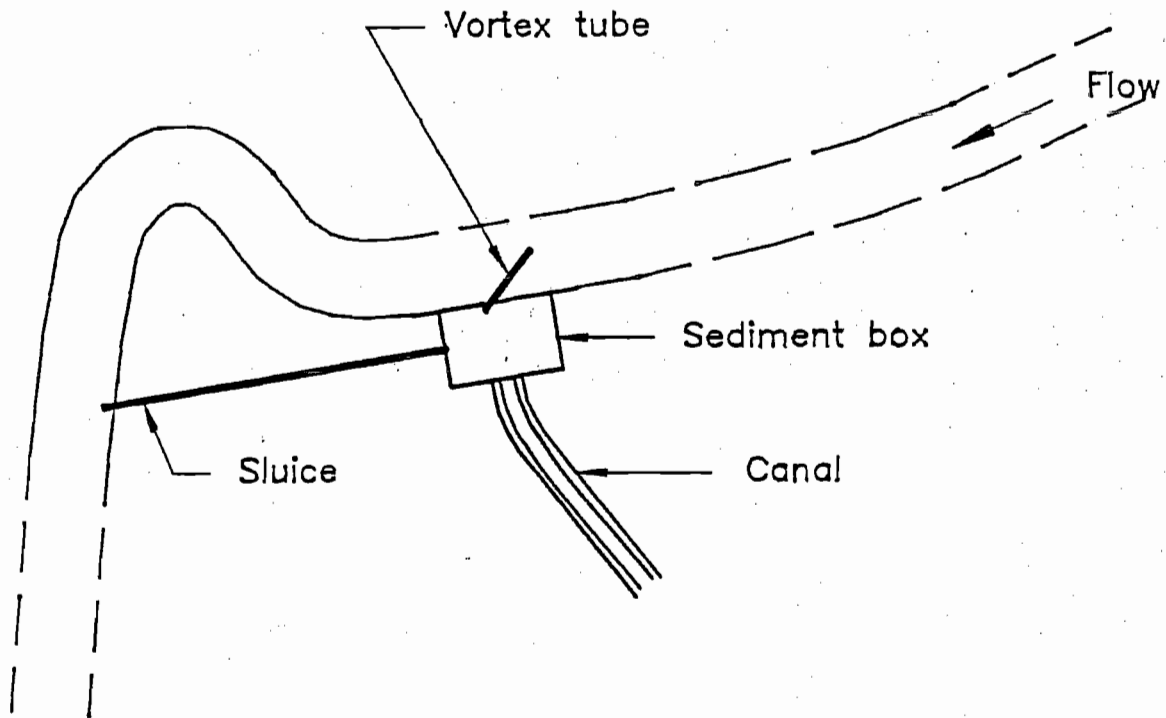

TYPICAL SITE PLAN

FIGURE 1.

IRRIGATION DIVERSION STRUCTURE VORTEX TUBE GALLERY

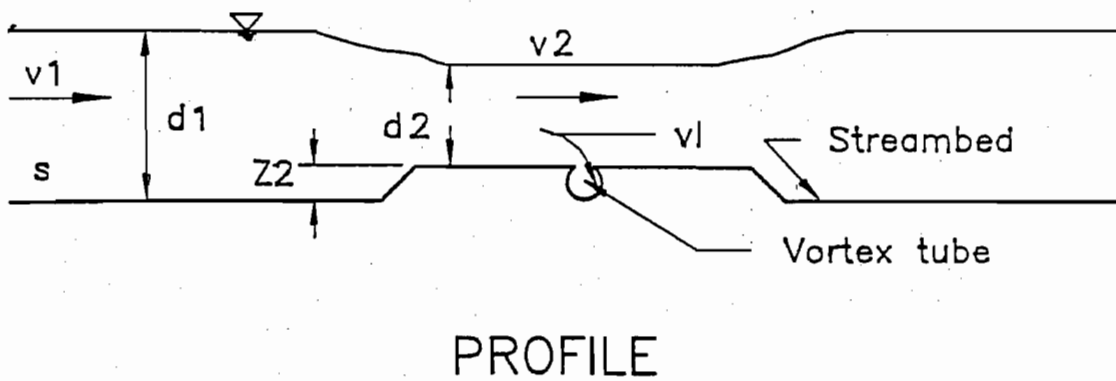
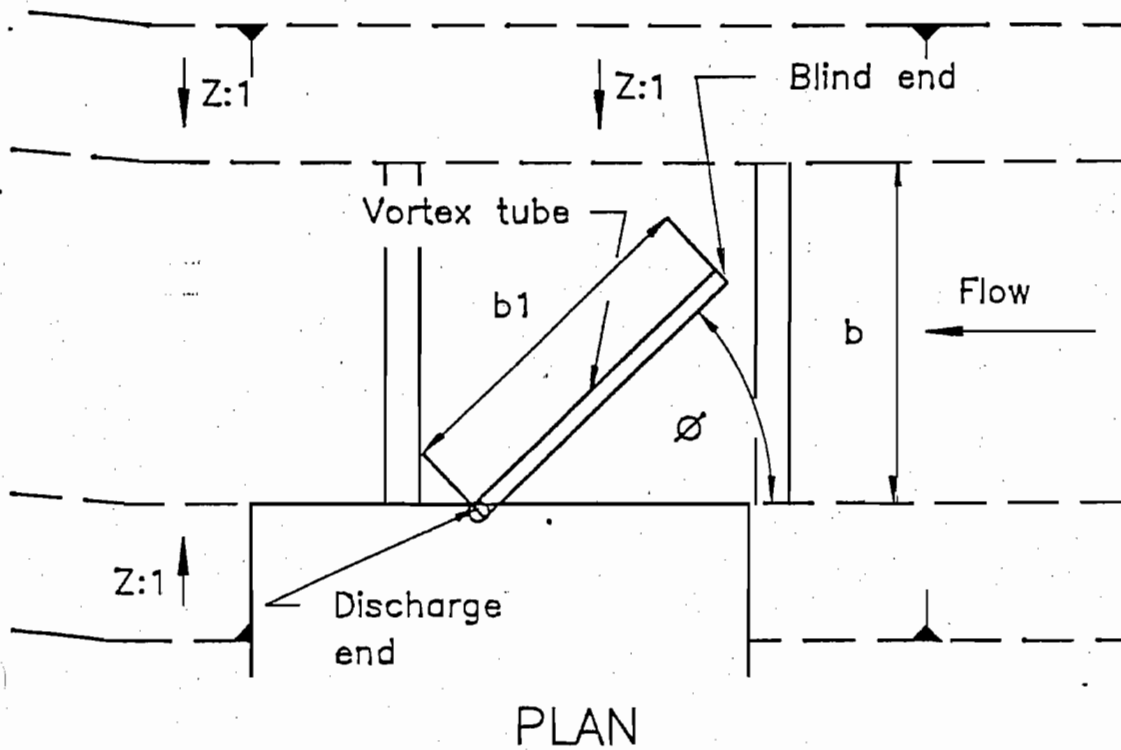
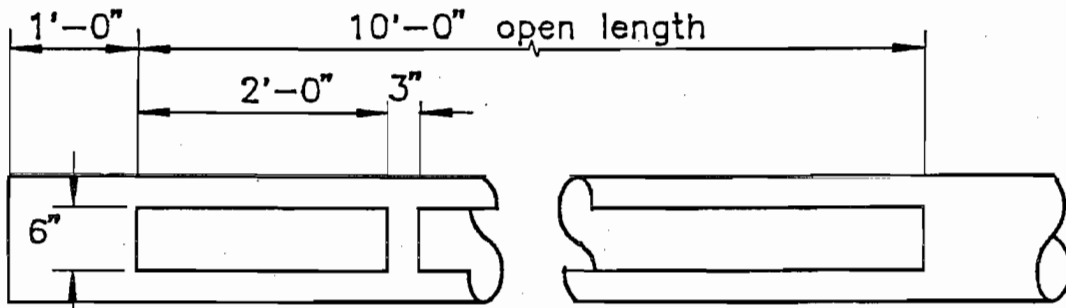
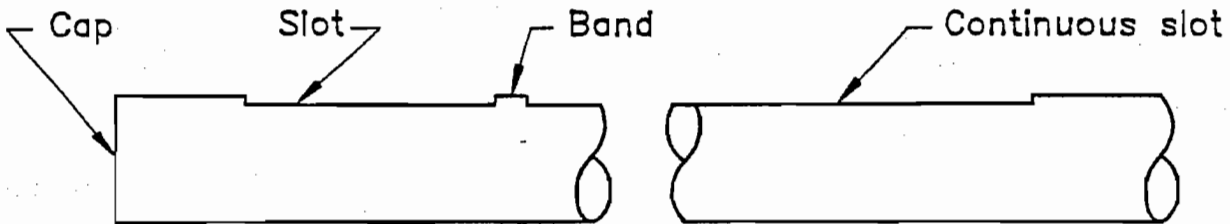

FIGURE 2

IRRIGATION DIVERSION STRUCTURE VORTEX TUBE GALLERY



PLAN



PROFILE

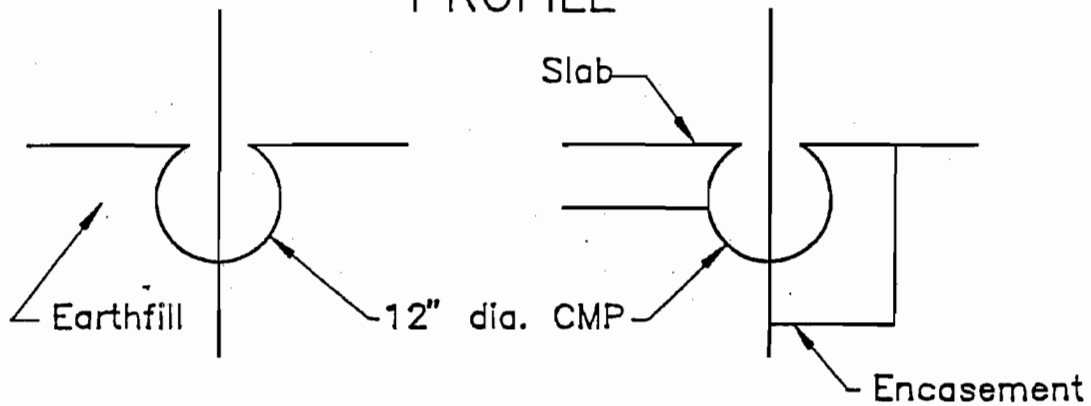

CROSS SECTIONS

ALTERNATE 1

ALTERNATE 2

FIGURE 3

IRRIGATION DIVERSION STRUCTURE
STEEL PLATE

Steel plate structures will be most applicable for the following conditions:

1. Low flow conditions where limited checking is needed to accomplish diversion of water.
2. Locations where flow conditions and access permit temporary installation and removal. Some attempts at modifying the structure for permanent installation are being made.
3. Locations where streambed material size is fine enough to permit relatively easy installation. Large cobble or boulders in the streambed would require special site preparation and installation methodology.
4. Structures should be limited to checking of two feet or less.

This concept was developed as an alternative diversion structure by the Montana Department of Fish, Wildlife, and Parks. It consists of a 4' x 8' x 1/4" steel plate with a 12 inch vertical steel plate cutoff on the upstream side. A series of these 8 foot long plates are placed end to end across the stream channel. These structures are normally temporary structures placed in the stream in the summer and taken out in the Fall. They permit checking of the water using collapsible flashboard guides and flashboards. Several of these installations have been made in Montana which will eventually permit evaluation of parameters for their use. See Figure No. 1 for details of the structure. The Soil Conservation Service has suggested a modified but similar structure to this. It has cutoffs on both upstream and downstream sides and is being proposed for permanent installation in some sites. See Figure No. 2 for details of this modified structure.

With several of these installations in place, further evaluation of the site and their performance will be possible and should be undertaken. This would provide a good evaluation of design criteria.

**IRRIGATION DIVERSION STRUCTURES
PLANNING AND DESIGN CONSIDERATIONS
STEEL PLATE**

1. Streambed Material
 - a. Best adapted to sand and gravel streambeds.
 - b. Finer grained more erodible materials may need rock protection or deeper cutoffs.
 - c. Cobble or boulder streambeds will require special installation methods.
2. Head Limitations - It is recommended that the maximum checked head be less than two feet.
3. Generally intended to be placed in the stream during low flow conditions. This structure may not be applicable and may be unstable during high flow conditions. It should generally be removed in the Fall so that it is not in the stream during high Spring runoff.
4. Installation - Relatively easy to install. Any contractor and many landowners would have equipment to install the plates. As presently used requires equipment in the streambed twice per year.
5. Checking of water will be accomplished by placing wood boards to the elevation needed. Checking should be limited to two feet in most cases.
6. Stability of the channel may need to be evaluated when using this type of structure. This is especially true when using as a wing deflector part way across the stream as opposed to a structure extending across the entire river.
7. Bank stability on the abutments should be addressed. Rock riprap of the abutments may be required.
8. Cost: \$200.00 - \$350.00 per 8 foot section. (\$25.00 - \$45.00 per square foot.)

**IRRIGATION DIVERSION STRUCTURE
DESIGN CRITERIA AND SPECIFICATIONS
STEEL PLATE**

1. It is recommended that specific criteria not be presented until evaluation of existing installations can be made.
2. Limit head to 2 feet.
3. Protect as needed to assure structure does not undercut and fail. Stability analysis of the stream channel may be required if extending structure only part way across channel.
4. There are no SCS design criteria or specifications developed for this type of structure. Standard SCS specifications for metalwork and for earthwork where applicable will apply. Typical structure details can be found on Page 44 of the West States Irrigation Diversion Structure Catalog dated April 29, 1991.

Additional information can be obtained from Mr. Al Wipperman, Montana Department of Fish, Wildlife and Parks and from the State Conservation Engineer, SCS, Bozeman, Montana.

IRRIGATION DIVERSION STRUCTURE STEEL PLATE

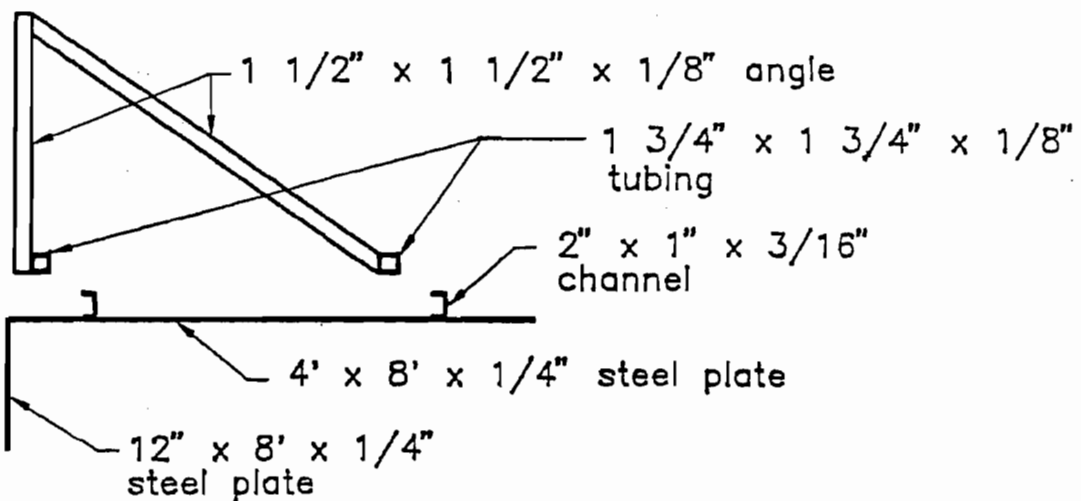
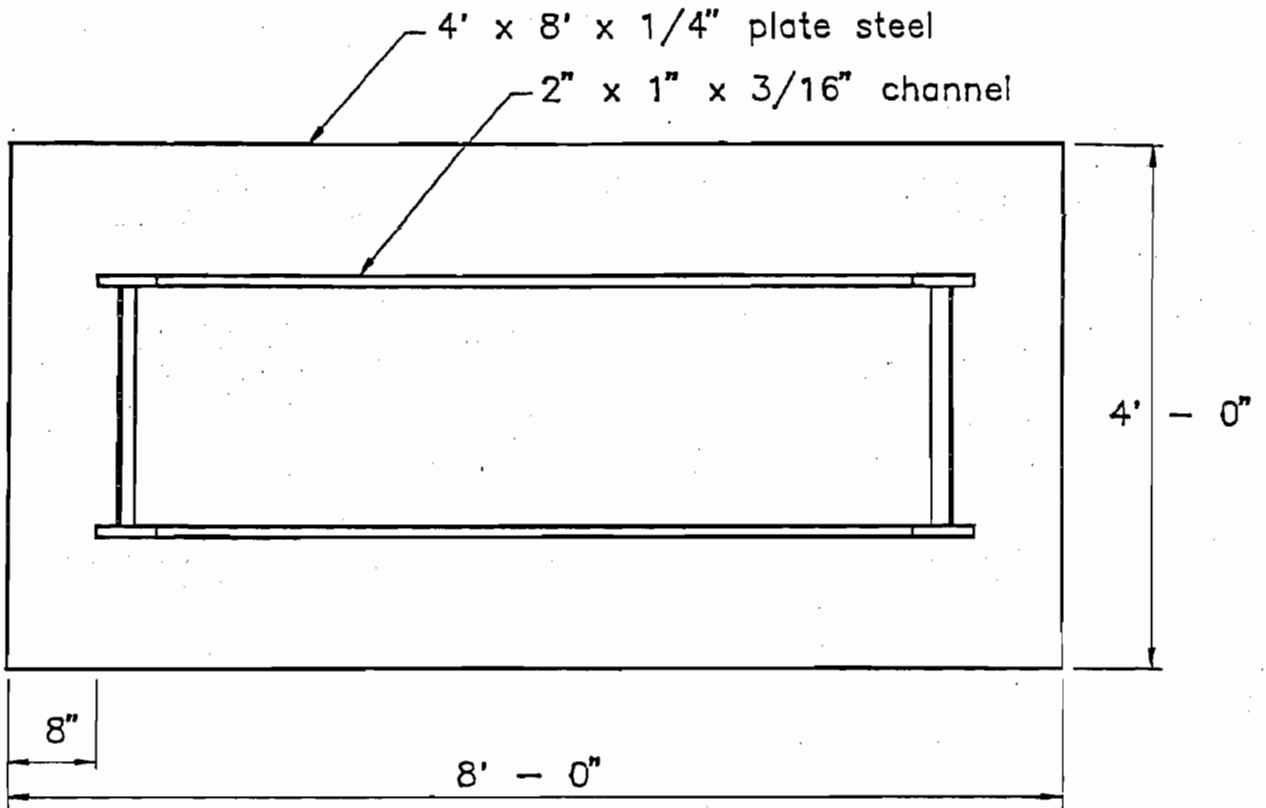

CROSS SECTION

MT DEPT OF FISH WILDLIFE & PARKS

FIGURE 1

IRRIGATION DIVERSION STRUCTURE STEEL PLATE

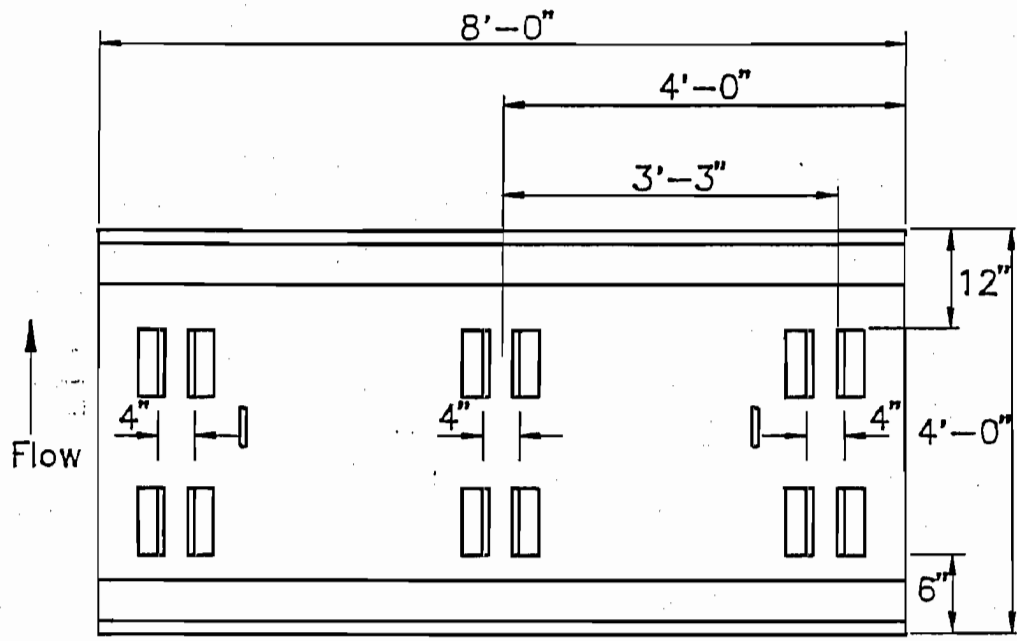

PLAN

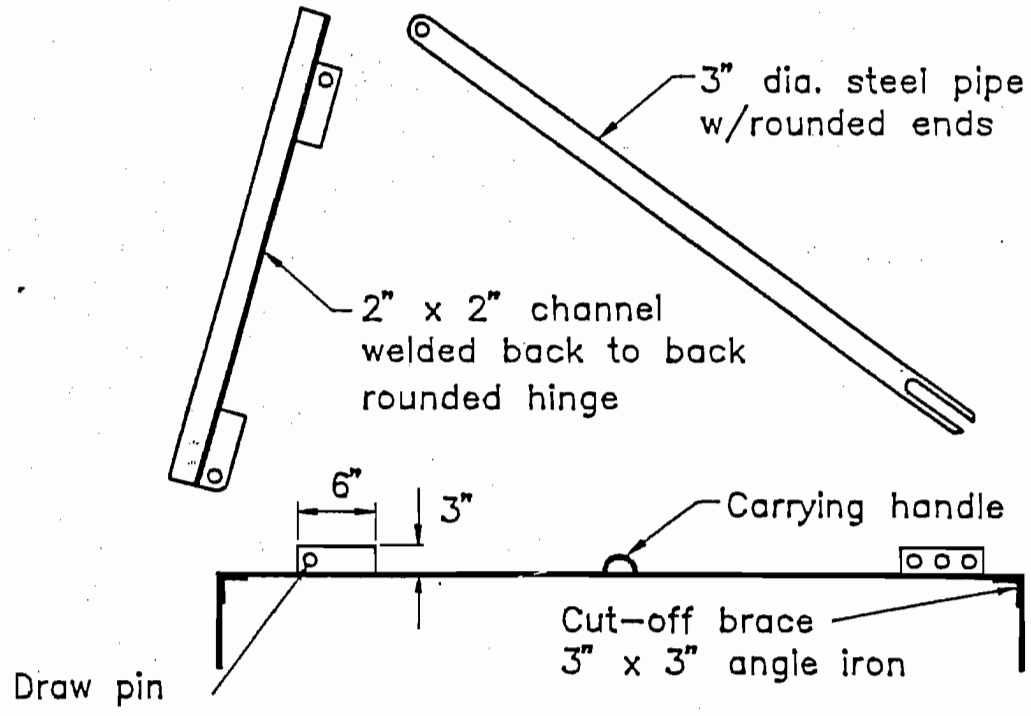

CROSS SECTION

SOIL CONSERVATION SERVICE

FIGURE 2

IRRIGATION DIVERSION STRUCTURE MASS FOUNDATION AND CHECK

A mass foundation and check diversion structure is used where it is necessary to raise the water surface in a waterway or stream, in order to divert all or part of the water to a different watercourse or irrigation canal. This type of structure consist of two major component parts. The check component consists of devices such as jacks, which temporarily raise and regulate the water level at the desired elevation. These check devices are discussed in more detail elsewhere in this report. The mass foundation is the permanent component of the structure that supports and anchors the checks and also may act to stabilize the channel at the point of diversion. The crest of the mass foundation is usually placed at or near the flow line of the channel. It must be constructed of a erosion resistant material and provide the required cutoff, length, height, bulk, etc. necessary to meet the design life of the structure. The mass foundation is the most costly component of the structure.

Reinforced concrete or treated timber have typically been used to construct the foundation component of this type of diversion structure. This concept consists of constructing the foundation as a mass utilizing locally available materials and/or construction methods not typically used for this type of structure such as: Roller Compacted Concrete, Non-reinforced Concrete, Grouted Rock Riprap, Soil Cement or Loose Rock. A more detailed description of each of these alternatives follows and typical sketches are shown in figure 1.

These same materials could be used in the construction of permanent check diversion structures as shown in figure 2 or combination of permanent and temporary check diversion structures. The temporary check diversion is generally considered the most desirable due to the fact that it tends to minimize the permanent effects of the diversion on the stream and fisheries. Channel hydraulics and owners desires may require the consideration of a combination permanent and temporary diversion structure. The combination diversion structure may be constructed by installing a permanent crest elevated above the channel bottom across the entire channel with check devices anchored to this permanent crest to further raise the water surface temporarily or a portion of the width of the diversion could be constructed with a permanent crest with check devices at channel bottom and the remainder of the width stair stepped up with a permanent crest.

Sketches of alternative methods of constructing the abutments are shown in figure 3.

RCC - ROLLER COMPACTED CONCRETE

This concept is relatively new. (Technology and design procedures are not readily available.) This concept may be of significant advantage at sites where there is a suitable source of aggregate materials available requiring little or no processing. A contractor with the knowledge and equipment to place a large volume of material in a relative short period of time is required. RCC contains the same basic ingredients as ordinary concrete (cementitious material, water, sand and aggregates), but differs in method of handling and mix design. The total quantity of cementitious material is much less than ordinary concrete. The water quantity is only that to obtain a workable dry mix with no slump. The cement, water, sand and aggregates are mixed in various kinds of mixers, delivered to the site by conveyor belt or dump trucks, placed with bulldozers in lifts 1 to 2 foot thick and compacted with vibrating rollers. The maximum size of coarse aggregate recommended is less than 3 inches.

SOIL CEMENT

Soil Cement is a compacted mixture of pulverized soil, cement and water. Methods of manufacture, handling and placement are similar to roller compacted concrete. It is recommended that the soil material all pass the 2 inch sieve and no more than 35 percent pass the 200 sieve and that portion of the soil passing the 200 sieve be nonplastic. Cement content is 10 to 13 percent of dry weight of the soil. Moisture content and density are determined by the moisture density test for soil cement (ASTM D558). Proper curing is important. Soil Cement gains its strength slowly and disturbance or vibration during the curing period should be avoided. Compressive strength of 500 to 1000 pounds per square inch in 7 days is common with a wide range of soils. Soil cement gains approximately 1/3 of its strength in 7 days. Soil cement will not obtain the compressive strengths or be as durable as roller compacted concrete or nonreinforced concrete. It should only be considered for use in channels with low velocities and that have a design life of less than 20 years.

NON-REINFORCED CONCRETE

The concept of non-reinforced concrete involves using ordinary concrete, with the possible exception of reducing the cement quantity and placing with a lower slump than normally used for formed concrete. Maximum of three inch coarse aggregate is recommended. No reinforcement steel would be used, the structure would be designed such that the concrete is placed primarily on flat or sloped surfaces requiring little or no forming and the thickness of the concrete would be at least twice that of formed reinforced concrete.

ROCK RIPRAP

Rock riprap has been frequently used in the construction of permanent check diversion structures. When there is a source of rock of adequate quality and gradation near the site, it will probably be the most economical material to use. There is little opportunity to use rock riprap as a foundation for temporary checks as the crest is irregular and there is no means to attach checking devices. Rock riprap could be effectively used in combination with one of the other materials when a temporary check diversion structure is required. A contractor with the equipment to handle large rock is required. The rock riprap gradation needs to be designed to resist displacement. The rock needs to be of a quality to serve the design life of the structure.

GROUTED ROCK RIPRAP

Grouted rock riprap consists of rock bound together by having voids filled with a cement grout to form a greater mass to resist pressures of water and prevent the rocks from being displaced. It permits the utilization of smaller rock and can reduce the quantity of rock required. The crest of the foundation can be constructed uniformly and checking devices may be anchored to the grouted rock for a temporary diversion structure. The thickness of grouted rock riprap compared to ordinary rock riprap can be reduced by 50 to 65 percent. The grout should penetrate into the rock 12 inches for thicker sections and a minimum of 8 inches. The grout usually consists of a good strength portland cement concrete using a maximum aggregate size of 3/4 inch and a slump of 3 to 4 inches.

IRRIGATION DIVERSION STRUCTURE
PLANNING AND DESIGN CONSIDERATIONS
MASS FOUNDATION AND CHECK

1. Streambed
 - a. Adaptable to all types of streambeds.
 - b. Structure Stability
 - (1) Extent of/or need for rock riprap below apron dependent on streambed material.
 - (2) Depth of cutoff dependent on streambed material.
 - (3) Velocity and flow characteristics - upstream and downstream.
 - c. Dewatering - Dry solid foundation required for construction of RCC, Soil Cement Foundations.
2. Head Required - Limited by check device or jacks.
3. Availability of Material
 - a. Availability of suitable material source near site required for alternative selected.
 - b. Feasibility of non-reinforced concrete or grouted rock may be dependent on relative location and distance to a source of concrete.
 - c. Concrete - Batch or ready-mix.
4. Availability of Equipment/Contractor
 - a. Does construction require specialized equipment such as mixers, conveyor belts, rollers.
 - b. Contractor availability with knowledge to place large volumes of material in a short period of time.
 - c. Contractor local or non-local.
5. Cost
 - a. Unit cost of material dependent on quantities of materials involved. Unit price will decrease greatly as required quantities increase, especially for RCC.
 - b. Unit cost for RCC, Non-reinforced Concrete, Soil Cement or Grouted Rock Riprap \$60 to \$150 per cubic yard (1991). Would be considered feasible alternative when less than \$100 per cubic yard. Unit cost of Rock Riprap \$15 to \$50 per cubic yard. Cost per foot width of typical apron type structure \$75 to \$200.
 - c. Shorter construction time resulting in reduced cost for engineering services.
6. Life - RCC and Non-reinforced Concrete would be considered a medium to long life structure. Soil Cement and Grouted Rock would be considered a medium life structure.

7. Construction Time - Actual time required for construction would be considerably less than other types of construction such as formed reinforced concrete.

**IRRIGATION DIVERSION STRUCTURE
DESIGN CRITERIA AND SPECIFICATIONS
MASS FOUNDATION AND CHECK**

Design criteria and specifications are available for each of the alternative concepts for mass foundation diversion structures. Some of these references are as follows:

1. Soil Conservation Service, Engineering Design Standards - Far West States, West National Technical Center, Portland, Oregon, 1970.
2. Soil Conservation Service, Drop Spillways NEH Section 11, Soil Conservation Service, Washington D.C.
3. Soil Conservation Service, Specifications for Construction Contracts NEH Section 20: Specification 61 - Loose Rock Riprap; Specification 62 - Grouted Rock Riprap, Soil Conservation Service, Washington D.C.
4. Design of Small Dams, Third Edition, USDI - Bureau of Reclamation
5. Specifications for Structural Concrete for Buildings (ACI 301-84), American Concrete Institute, Detroit, Michigan
6. Bank and Shore Protection in California Highway Practice, State of California, Department of Public Works, Division of Highways, Sacramento, California
7. West States Irrigation Diversion Structure Catalog, Soil Conservation Service, West National Technical Center, Portland, Oregon.
8. Portland Cement Association, Soil Cement Slope Construction Handbook EB003.09s, Portland Cement Association, Skokie Illinois, 1979
9. Portland Cement Association, Soil Cement Slope Protection for Embankments: Planning and Design, IS173.02W, Portland Cement Association, Skokie Illinois, 1975
10. REC-ERC-7I-20 "Soil Cement Slope Protection on Bureau of Reclamation Features, USDI, Bureau of Reclamation, Denver, Colorado, 1971
11. REC-ERC-B4-IS "Mix Design Investigation-Roller Compacted Concrete Construction-Upper Stillwater Dam, Utah, USDI, Bureau of Reclamation, 1984
12. REC-ERC-B4-2S "Performance of Soil Cement Dam Facings - 20 - year Report, 1984

13. ACER Technical Memorandum No. 8 Guidelines for Designing and Constructing Roller-Compacted Concrete Dams, USDI-Bureau of Reclamation, Denver, Colorado, 1987

IRRIGATION DIVERSION STRUCTURE MASS FOUNDATION

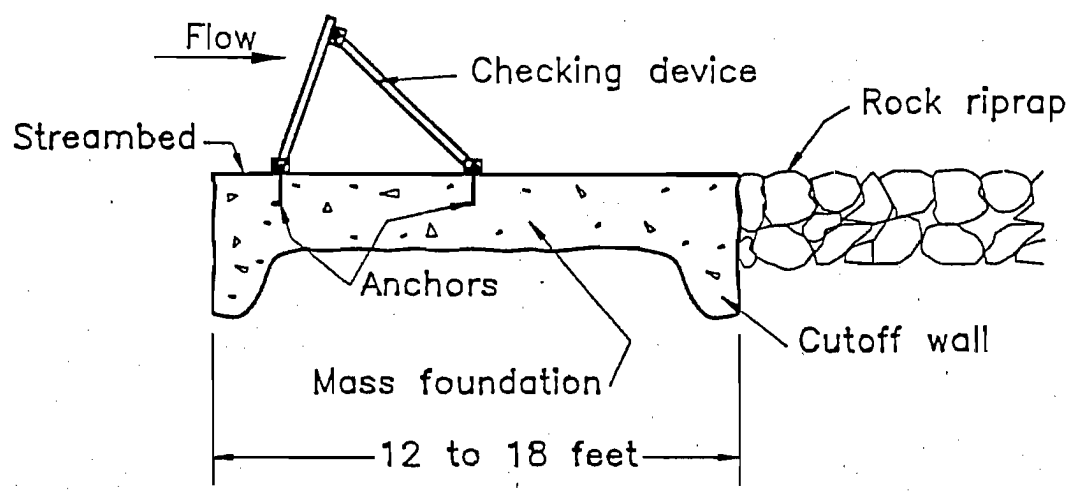

TYPICAL SECTION

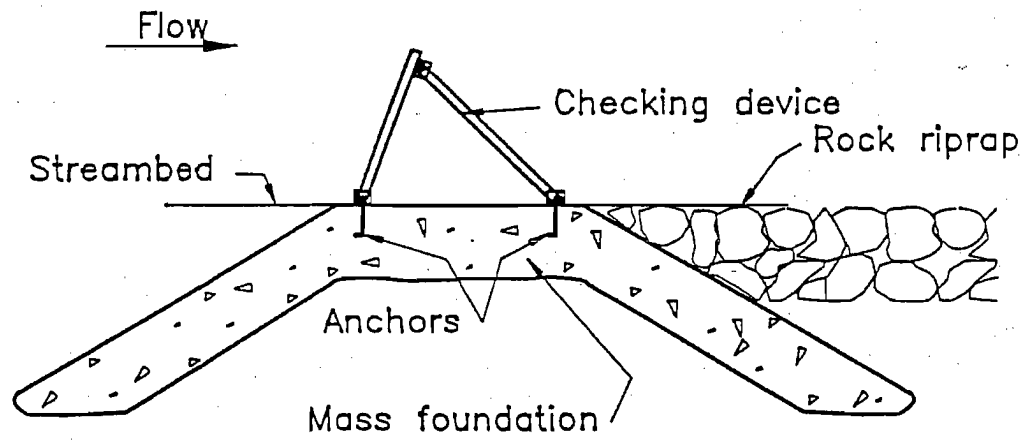

ALTERNATE SECTION

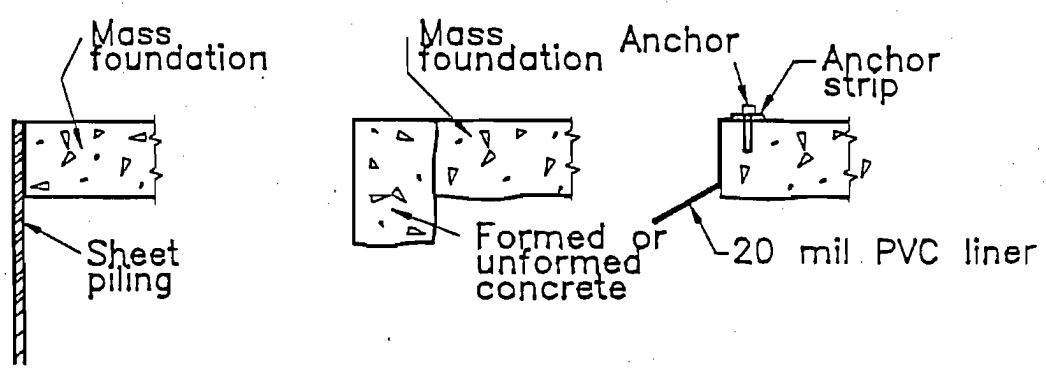

ALTERNATE CUTOFF WALLS
FIGURE 1

IRRIGATION DIVERSION STRUCTURE MASS FOUNDATION

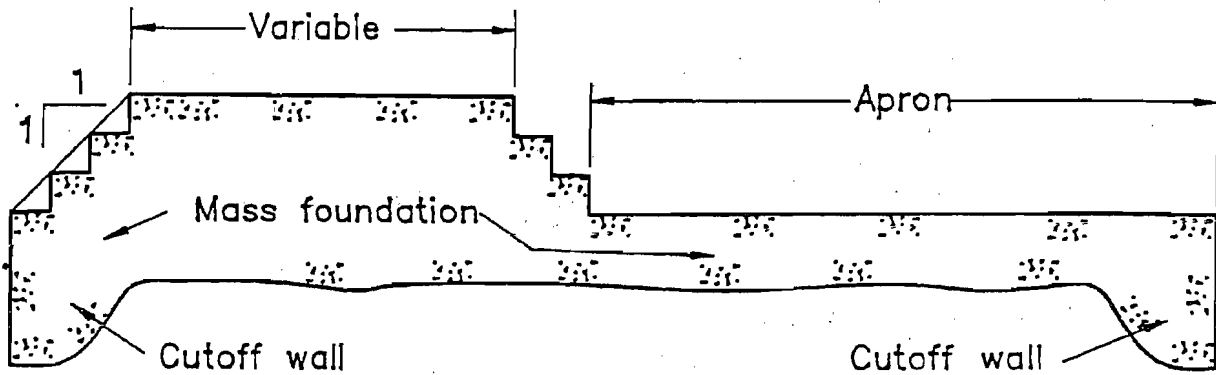

TYPICAL SECTION CONCRETE PERMANENT CHECK

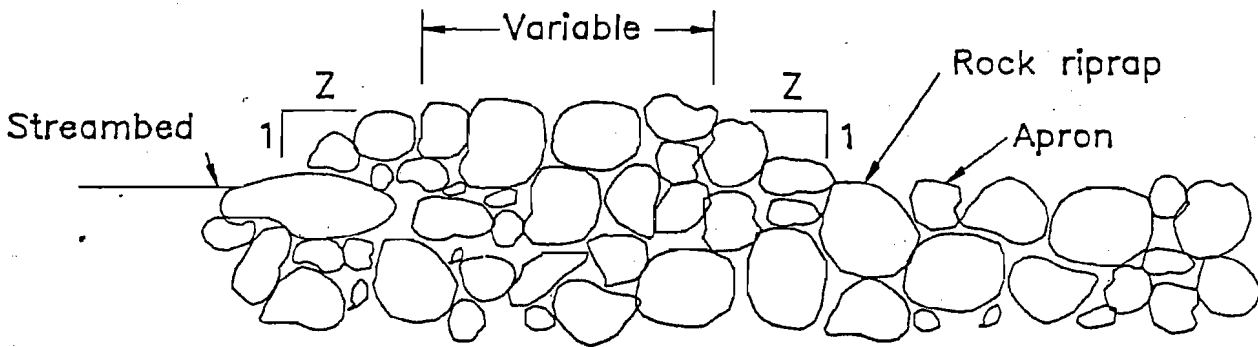

TYPICAL SECTION ROCK RIPRAP PERMANENT CHECK

FIGURE 2

IRRIGATION DIVERSION STRUCTURE MASS FOUNDATION ABUTMENT ALTERNATIVES

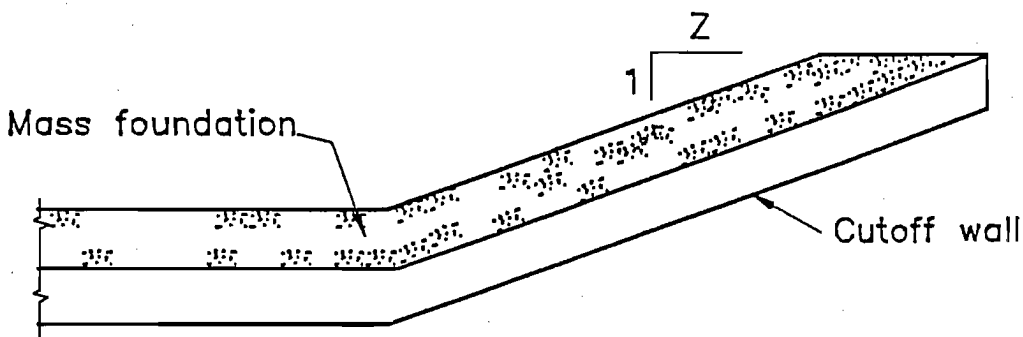

SLOPED ABUTMENT

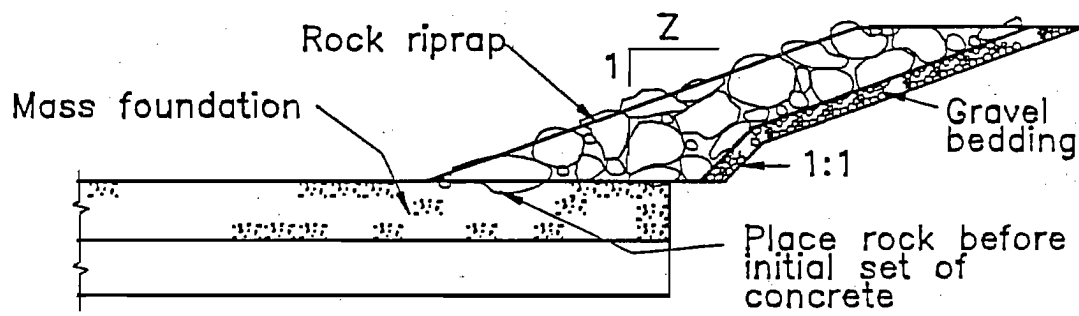

ROCK RIPRAP ABUTMENT

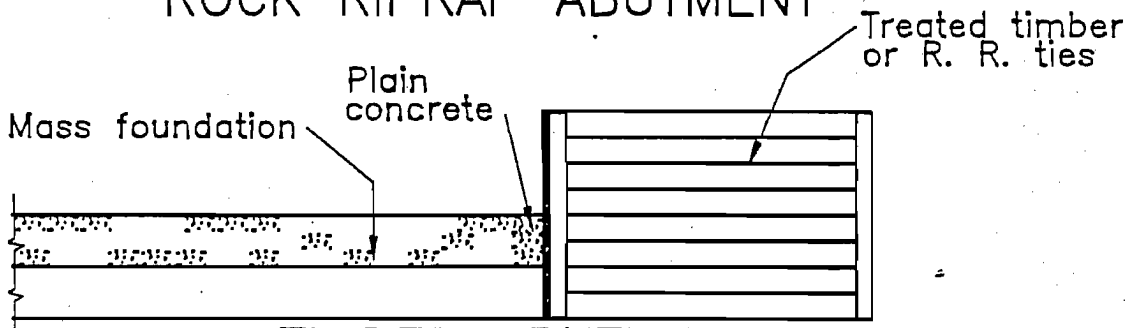

TIMBER ABUTMENT

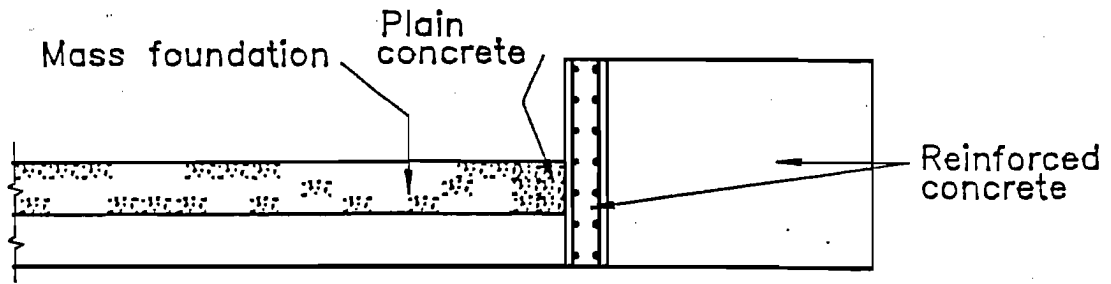

REINFORCED CONCRETE ABUTMENT
FIGURE 3

IRRIGATION DIVERSION STRUCTURE PILE/POST FOUNDATION AND CHECK

This concept consists of placing piles or posts across the stream bed for attaching a removable check structure. This type of structure is best suited where low cost piles or posts are available; low cost labor is available; and the streambed material is suitable for driving piles or excavating for the placement of posts. A permanent sill should be secured to the top of the pile or posts to provide a base for the checks. The check structure may be removed when not diverting for irrigation. A plan and profile of a typical installation is shown in figure 1.

PILE/POST FOUNDATION

The typical pile/post foundation would consist of steel or timber piles or posts placed as shown in the cross sections in figure 2. The piles would normally be driven into the stream bed with a pile driver or pushed in with excavation equipment if the soil is soft enough. Posts or piles can be placed after excavating the streambed to the depth desired. Placement details of driven or excavated posts and piles are given in figure 3. The depth L of the pile or post is dependent upon the lateral forces acting upon the members and the properties of the soil. Cutoff depth required to prevent seepage and piping failure should be considered. If the piles are interlocking seepage or piping protection will be provided to the full depth. Cutoff protection may have to be provided independently in the case of post construction such as through the use of horizontal interlocking members or geotextiles supported on a structural frame. The line of the piles or posts should be extended on either side of the toe of slope a sufficient distance W to prevent bank erosion.

CHECKS

Checks may be permanent or temporary. Permanent checks would generally be an extension of the pile or post line to the elevation desired. Temporary checks are removable and may be constructed of a variety of materials. Removable checks are discussed later in the report.

IRRIGATION DIVERSION STRUCTURE
PLANNING AND DESIGN CONSIDERATIONS
PILE/POST FOUNDATION AND CHECK

1. Streambed material
 - a. Type. The streambed material can be clay, silt, sand, or gravel.
 - b. Size. The maximum size streambed material should be less than 6 inches if the piles are to be driven.
2. Streamflow
 - a. Upstream conditions should be considered to determine if backwater is a problem.
 - b. Downstream erosion control should be designed for the diversion based on downstream velocities.
3. Stream depth
 - a. The stream depth should be approximately the same as the head on the structure to avoid flooding upstream or loss of the structure through overtopping.
4. Foundation cutoff
 - a. A foundation cutoff should be considered for spaced piles or posts.
5. Pile/post depth
 - a. Pile/post depth should be in accordance with structural needs and foundation material.
6. Checks
 - a. The checks should be types suitable for use with piles and posts.
7. Cost and availability of material
 - a. If low cost timber or used steel piles or posts are available and the streambed material is somewhat soft then the costs should be low for the 3 foot head design. The costs would be higher for new steel piles or posts, firm foundations, and higher heads.

IRRIGATION DIVERSION STRUCTURE
DESIGN CRITERIA AND SPECIFICATIONS
PILE/POST FOUNDATION AND CHECK

Design Criteria.

References:

1. American Institute of Steel Construction, Inc., Manual of Steel Construction, 9th ed., AISC, Chicago, Illinois, 1989.
2. American Institute of Timber Construction, Timber Construction Manual 3rd ed., John Wiley & Sons, NY, 1985.
3. American Wood-Preservers' Association, Standards 1990, American Wood-Preservers' Association, Stevensville, Maryland, 1990.
4. Dawkins W. P., Design/Analysis of Sheet Pile Walls by Classical Methods - CSHTWAL (X0031), U.S. Army Engineer Waterways Experiment Station, Vicksburg, Mississippi, 1979.
5. Foundation Sciences, Inc., Retaining Wall Design Guide, National Technical Information Service, U.S. Department of Commerce, Springfield Virginia, 1979.
6. Soil Conservation Service, Engineering Design Standards Far West States, West National Technical Center, Portland, Oregon, 1970.
7. Soil Conservation Service, National Handbook of Conservation Practices, Dam, Diversion 348, Soil Conservation Service, Washington DC, 1977.
8. Soil Conservation Service, National Engineering Handbook Section 5 Hydraulics, Soil Conservation Service, Washington DC,
9. Soil Conservation Service, National Engineering Handbook Section 6 Structural Design, Soil Conservation Service, Washington DC,
10. United States Steel Corporation, Sheet Steel Piling Handbook, USS, Pittsburgh, Pennsylvania, 1976.
11. United States Steel Corporation, USS Sheet Steel Piling Design Manual, USS, Pittsburgh, Pennsylvania, 1975.
12. Western Woods Products Association, Western Woods Use Book 3rd ed., Western Woods Products Association, Portland, Oregon, 1983.

Specifications:

1. Soil Conservation Service, National Handbook of Conservation Practices, Dam, Diversion 348, Soil Conservation Service, Washington DC, 1977.
2. Soil Conservation Service, National Engineering Handbook Section 20 Specifications for Construction Contracts, Soil Conservation Service, Washington DC,
3. Western Wood Preservers Institute, Guide to the Characteristics, Use, and Specifications of Pressure-Treated Wood, Western Wood Preservers Institute, Vancouver, Washington, 1990.

IRRIGATION DIVERSION STRUCTURE PILE/POST FOUNDATION

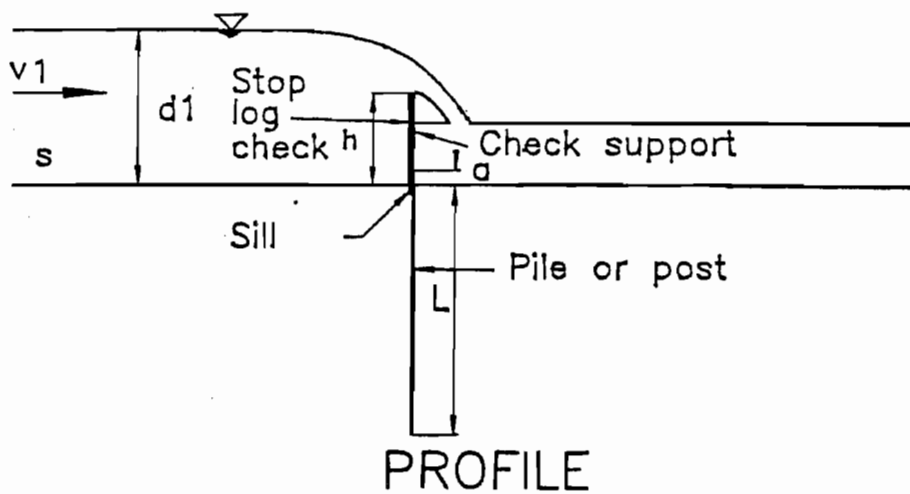
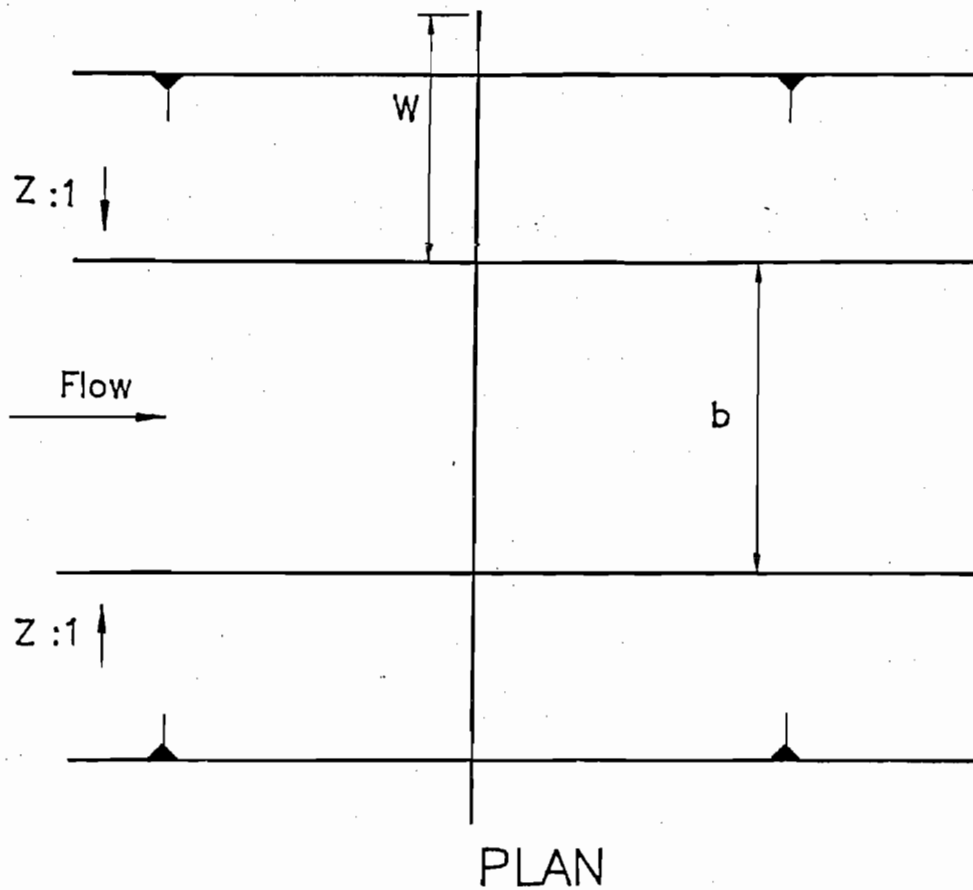
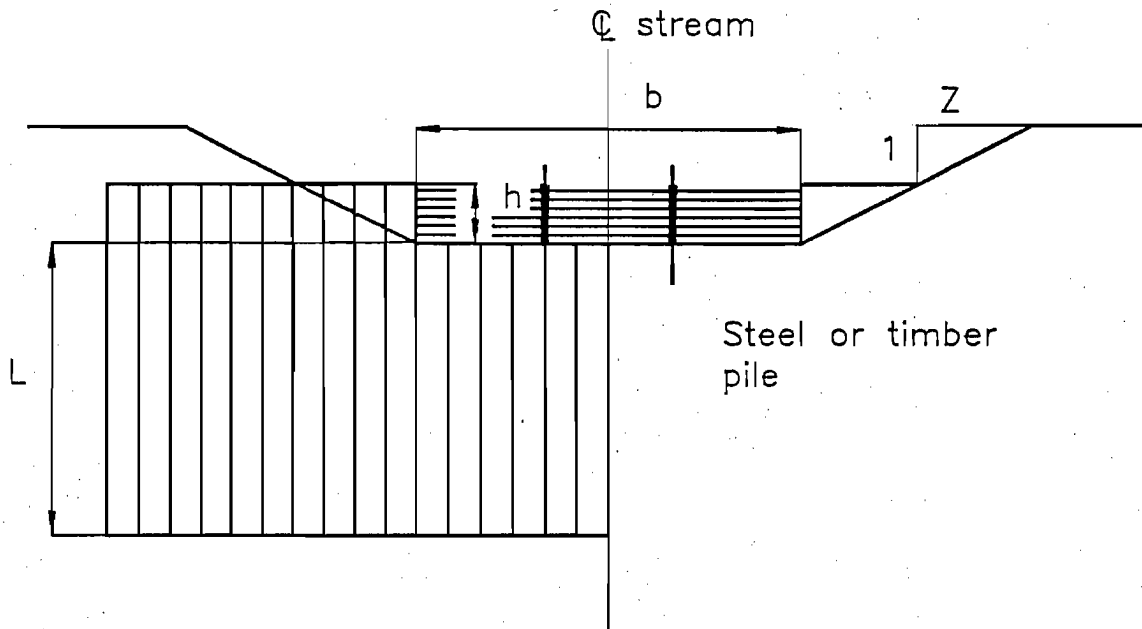
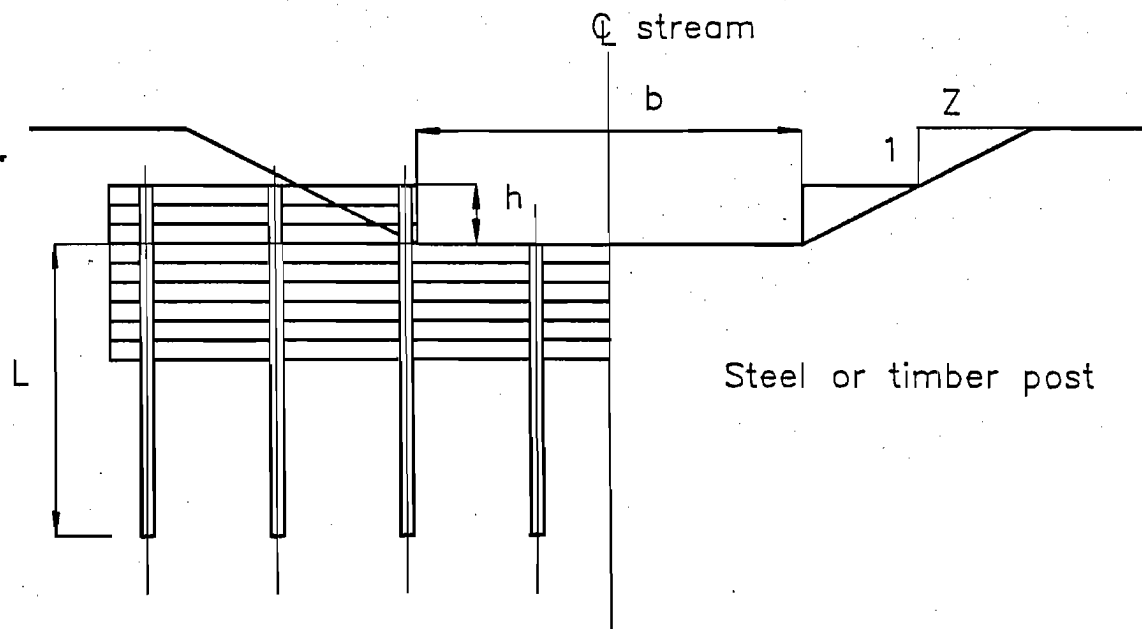

FIGURE 1

IRRIGATION DIVERSION STRUCTURE PILE/POST FOUNDATION



CROSS SECTION



CROSS SECTION

FIGURE 2

IRRIGATION DIVERSION STRUCTURE PILE/POST FOUNDATION

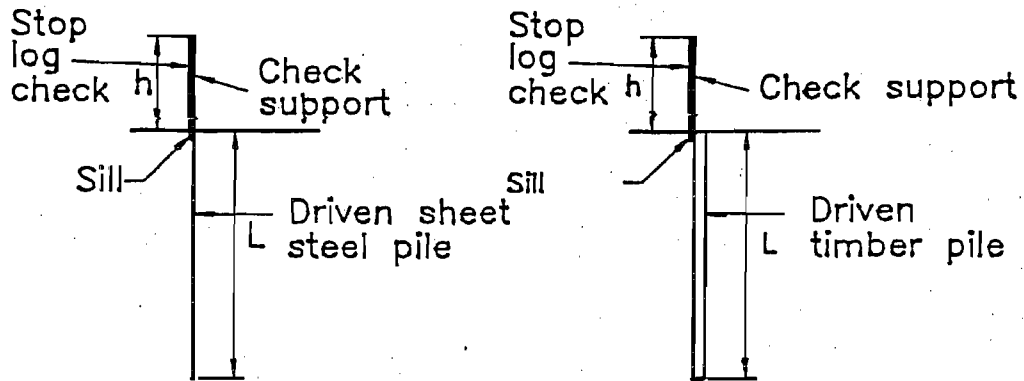

STEEL

TIMBER

PILE FOUNDATION AND CHECK

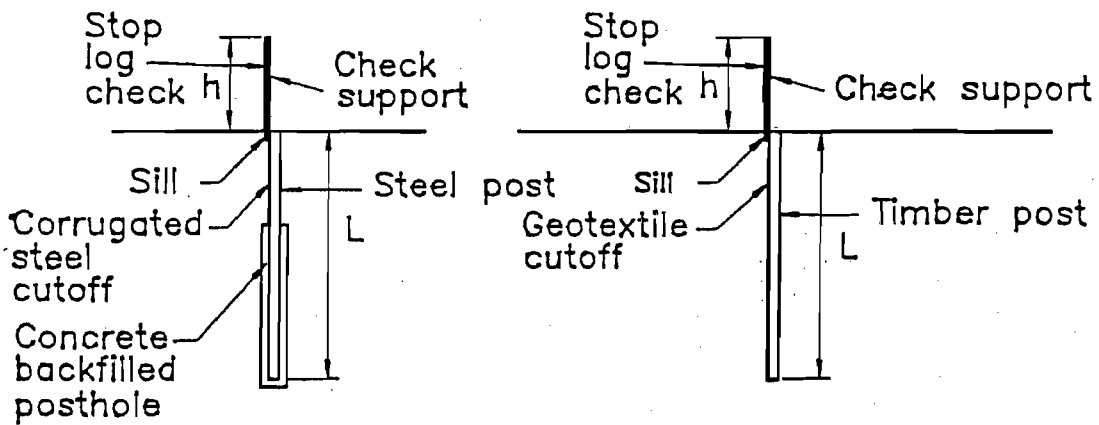

STEEL

TIMBER

POST FOUNDATION AND CHECK

FIGURE 3

IRRIGATION DIVERSION STRUCTURE PUMP

INTRODUCTION

This concept consists of using a pump to lift the required water from the source. Typical pump installations are the sump (figure 1) and the suction (figure 2). The water can be discharged into an open channel for transmission or conveyed to its final destination by an enclosed conduit. This alternative is best suited for situations where (1) the elevation of the water source is below the destination elevation, (2) wide streams, or (3) the flow to be diverted is relatively small.

PUMP TYPES

Several different types of pumps are available that can meet the requirements for diverting irrigation water. These include the axial flow (propeller), radial flow (centrifugal), and mixed-flow.

Axial flow or propeller pumps. This type of pump develops head by the lifting action of the impeller vanes on the water. The impeller consists of comparatively flat open blades on a small hub, similar to a ship's propeller, but which is mounted on a shaft within a tubular housing.

Radial flow or centrifugal pumps. This type of pump develops head by the action of centrifugal force. Volute type centrifugal pumps have spiral shaped casings with gradually enlarging cross section toward the discharge. Turbine type centrifugal pumps have fixed expanding vanes within a tubular housing.

Mixed flow pumps. This type of pump develops head by the combined effects of the lifting action of the impeller and centrifugal force.

SELECTION OF PUMP

A single stage axial flow pump is most suited to pumping heads of 10 feet or less. Flow capacities can range from a 100 to over 100,000 gpm. Axial flow pumps do not require priming and can handle silt and the passage of small trash without plugging. A disadvantage of this type of pump is that discharge drops off rapidly at heads above the design head and horsepower can increase significantly at or near the shut-off head. Also large size pumps may necessitate unusually deep sumps to provide sufficient submergence of the impeller.

Radial pumps are suited to pumping heads of 20 to 200+ feet. Flow capacities can range from 10 to 10,000+ gpm. Volute

centrifugal pumps are limited to locations where the suction lift is less than 20 feet. Centrifugal pumps must be primed before the pump will operate. Turbine pump installations require a sump.

Mixed flow pumps are suited to pumping heads of 10 to 90 feet. Flow capacities can range from 1,000 to 100,000+ gpm.

Multiple stage pumps are used when sufficient head cannot be developed efficiently in one stage. These pumps have two or more impellers operating in series; that is, the discharge of one impeller is connected to the suction of the next impeller. Propeller pumps are normally single stage.

**IRRIGATION DIVERSION STRUCTURE
PLANNING AND DESIGN CONSIDERATIONS
PUMP**

1. Streambed Material - Pump diversions are applicable to all types of streams.
2. Streamflow - The pump intake should be located to prevent damage from bedload, floating debris, and high and/or swirling stream velocities.
3. Head Required
 - a. The water depth over the pump intake must be sufficient to prevent vortex action.
 - b. Elevation between water source and discharge.
4. Sump
 - a. Location
 - b. Size
 - c. Screening requirements
 - d. Housing/shade for pump and motor
 - e. Type and number of pumps
5. Power Requirements
 - a. Power source (electricity, natural gas, diesel, gasoline, solar)
 - b. Permanent or portable
6. Operation and Maintenance
 - a. Annual power cost
 - b. Pumping plant controls and valving
 - c. Accessibility to site
7. Cost - The cost of pump diversion will vary according to the size (flow being pumped) of the installation. The cost of the pump, motor, swap, controls, and screen need to be evaluated.

IRRIGATION DIVERSION STRUCTURE
DESIGN CRITERIA AND SPECIFICATIONS
PUMP

General

The design of pump irrigation diversions is site specific depending upon the flow and pumping head. The size and number of pumps are determined from the required pumping plant capacity. A single farm may get by with one pump. However, on large systems, it is advantageous to have two or more pumps. Multiple pumps provide efficient pumping over a wider range of flow requirements and the breakdown of one pump does not stop all pumping. Experience has shown that in a system with two pumps, the capacity of the larger pump should be about twice the capacity of the smaller pump.

Design References

Soil Conservation Service, NEH Section 15, Irrigation, Chapter 8, Pumping Plants, Soil Conservation Service, Washington, D.C.

Soil Conservation Service, NEH Section 16, Drainage Agricultural Lands, Chapter 7, Drainage Pumping, Soil Conservation Service, Washington, D.C.

Hydraulic Institute Standards for Centrifugal, Rotary, and Reciprocating Pumps, Hydraulic Institute, 712 Lakewood Center North, 14600 Detroit Avenue, Cleveland, Ohio 44107

Pump Manufacturer's References

See Hydraulic Institute Standards for Centrifugal, Rotary, and Reciprocating Pumps above for manufacturer's names and locations.

IRRIGATION DIVERSION STRUCTURE PUMP

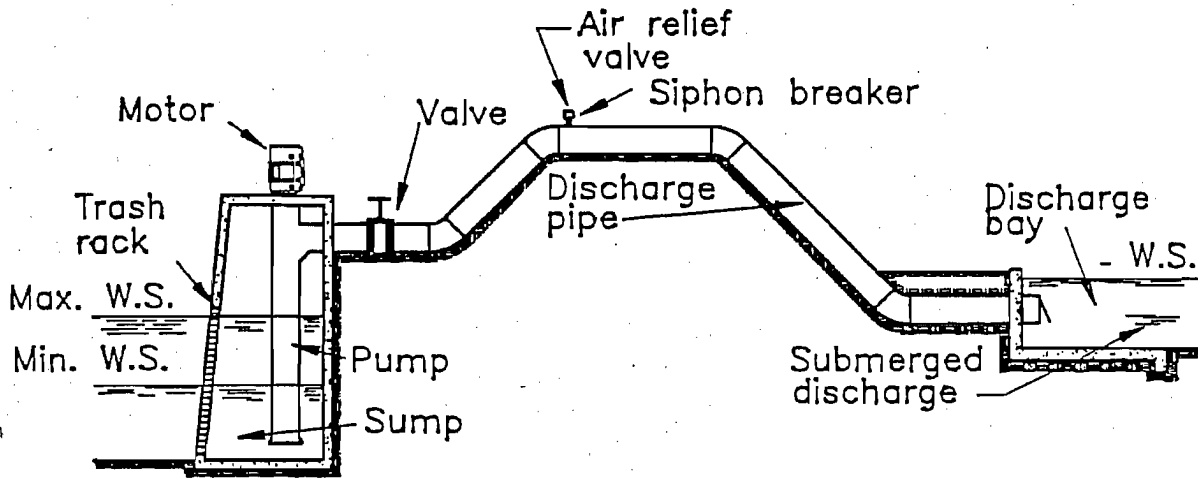

TYPICAL SUMP INSTALLATION

FIGURE 1

IRRIGATION DIVERSION STRUCTURE PUMP

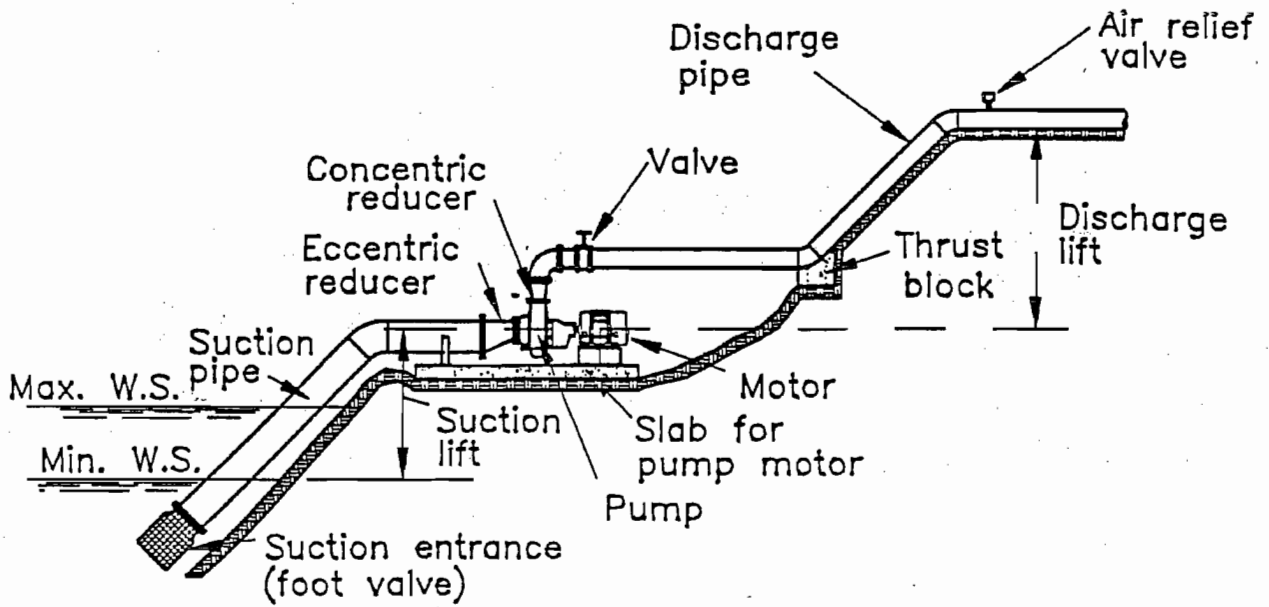

TYPICAL SUCTION INSTALLATION

FIGURE 2

Appendix III
Checks

IRRIGATION DIVERSION STRUCTURE
DESIGN CRITERIA AND SPECIFICATIONS
JACK AND STOPLOG/TIMBER CHECK

Description:

Jacks with stoplogs or timbers consist of a series of supports usually steel beams, pipe, or other fabricated members. Wood stoplogs or timbers are placed across the supports to the desired check elevation. The system is normally installed on a concrete, timber, or steel structure or base. See figure 1. The supports may be either rigid or collapsible. When designed as a collapsible support a hinged or pinned connection is used to allow manual collapsing of the check for passage of high flows. Supports are generally placed on four to eight foot centers.

References:

1. Soil Conservation Service, National Engineering Handbook Section 5 Hydraulics, Soil Conservation Service, Washington D.C.
2. Soil Conservation Service, National Engineering Handbook Section 6 Structural Design, Soil Conservation Service, Washington D.C.
3. Soil Conservation Service, West States Irrigation Diversion Structure Catalog, SCS, WNTC, 511 NW Broadway, Room 248, Portland, Oregon 97209-3489.

Costs:

The approximate unit cost for jacks with stoplogs or timbers is \$50 to \$100 per foot.

Installation Considerations:

1. The materials are relatively light.
2. Limited dewatering of the site would be required to complete the project.

IRRIGATION DIVERSION STRUCTURE JACK AND STOPLOG/TIMBER CHECK

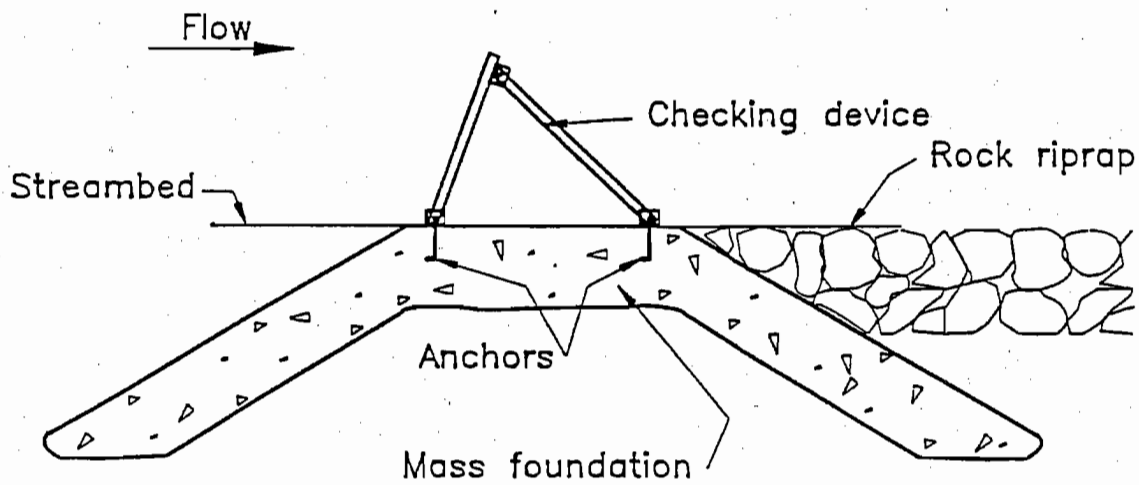

FIGURE 1

**IRRIGATION DIVERSION STRUCTURE
DESIGN CRITERIA AND SPECIFICATIONS
INFLATABLE FABRIC CHECK**

Description:

Inflatable fabric checks are commercially developed fabric bladders attached to a concrete foundation. See figure 2. The fabric dam can be inflated during low water periods to build up head for irrigation water diversion. During high flows the dam is deflated and lays flat on the foundation. The dams are filled with either air or water. Some type of system, such as a compressor or pump, must be available for inflation purposes. The concept is adaptable to varied sites where someone would be available to deflate the bladder if high water occurred. If the bladder was inflated during passage of high water, flooding and damage to adjacent property could result.

References:

1. Soil Conservation Service, National Engineering Handbook Section 5 Hydraulics, Soil Conservation Service, Washington D.C.
2. Soil Conservation Service, National Engineering Handbook Section 6 Structural Design, Soil Conservation Service, Washington D.C.
3. Bridgestone Corporation, 5900 Wilshire Boulevard, Los Angeles, California 90036

Costs:

The approximate unit cost for inflatable a fabric dam is \$3000 per foot.

Installation Considerations:

1. A simple foundation (usually concrete) is required.
2. Equipment to handle the rubber dam is required.

IRRIGATION DIVERSION STRUCTURE INFLATABLE FABRIC CHECK

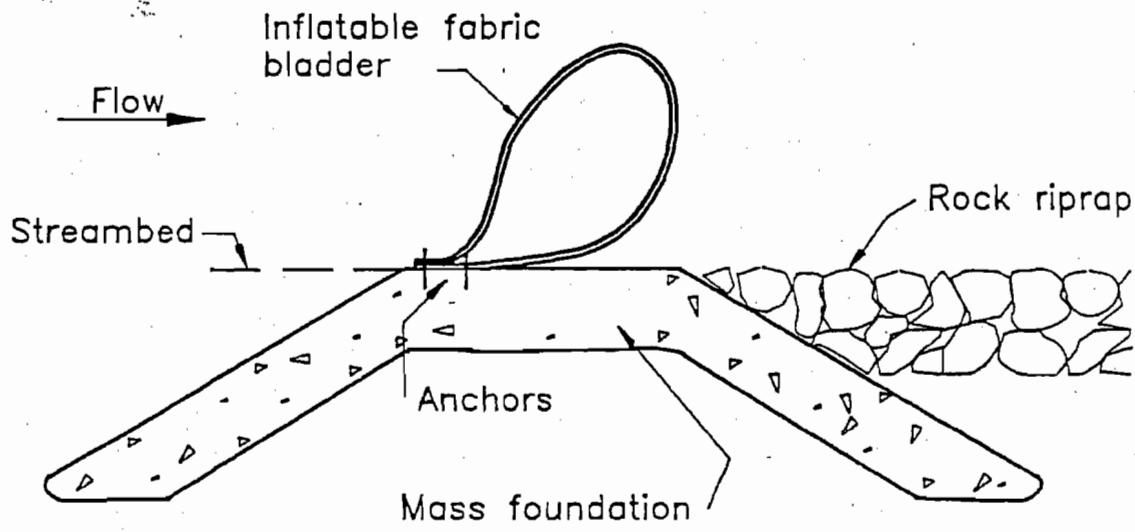

FIGURE 2

IRRIGATION DIVERSION STRUCTURE
DESIGN CRITERIA AND SPECIFICATIONS
LOG CHECK

Description:

A log check consists of using utility poles of tree logs as the water checking device. See figure 3. The logs may span all or a portion of the stream. The placement and removal of the logs will require equipment handling.

References.

1. Soil Conservation Service, National Engineering Handbook, Section 5 Hydraulics, Soil Conservation Service, Washington D.C.
2. Soil Conservation Service, Engineering Design Standards, Far West States, West National Technical Center, Portland Oregon, 1970.
3. American Society of Agricultural Engineers, Engineering Practice 388.2 Design Properties of Round, Sawn, and Laminated Preservatively Treated Construction Poles and Posts, American Society of Agricultural Engineers, 2950 Niles Road, St. Joseph, Michigan.
4. Timber Construction Manual, American Institute of Timber Construction, Washington, D.C.

Costs:

The approximate unit costs for logs or poles will vary locally as to availability of materials. Typical costs will be \$5 to \$15 per foot.

Installation Considerations:

1. Requires foundation structure or erosion resistance in natural stream bottoms.
2. The ends of the logs must be tied into the banks or walls of the foundation structure.
3. Equipment needs for lifting and placing logs or poles across the stream and their subsequent removal.
4. Limit installation to sites where minimal adjustment is needed in the checked water depth through the irrigation season.

IRRIGATION DIVERSION STRUCTURE LOG CHECK

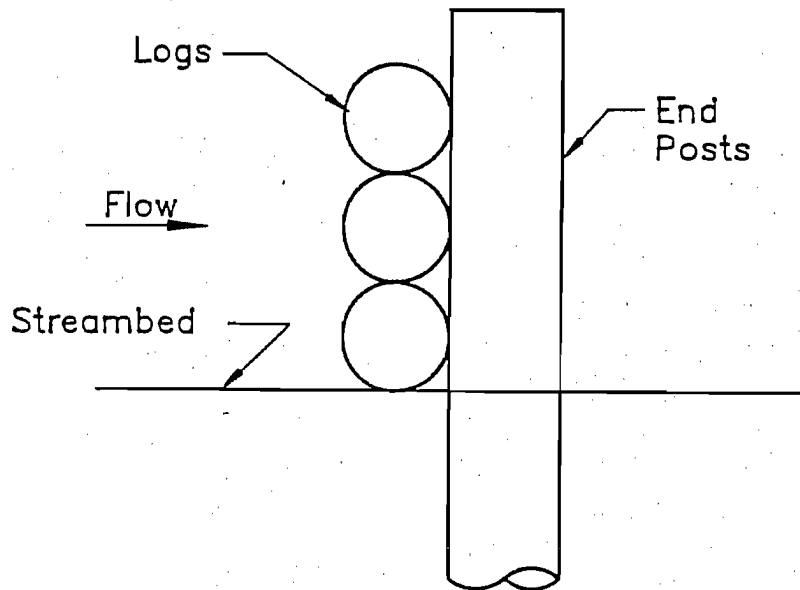

FIGURE 3

**IRRIGATION DIVERSION STRUCTURE
DESIGN CRITERIA AND SPECIFICATIONS
LIFT PANEL CHECK**

Description:

The lift panel check, also called overshot gate, consists of a gate leaf, hinge, and hoist mechanism. See figure 4. In a fully opened position the gate leaf is horizontal and permits full flow through the channel. The flow is reduced as the cable hoist raises the downstream edge of the gate. The maximum position of the gate is 60 degrees. The gate can be set at any position between 0 and 60 degrees to set the head for the diversion flow.

References:

1. Soil Conservation Service, National Engineering Handbook Section 5 Hydraulics, Soil Conservation Service, Washington D.C.
2. Soil Conservation Service, National Engineering Handbook Section 6 Structural Design, Soil Conservation Service, Washington D.C.
3. Armtec Water Control Products, 2023 North Gateway Ave, Fresno California, 93727, 1-800-955-9587

Costs:

The approximate cost for a 10 foot wide gate with a 3 foot head is \$3000 to \$4000.

Installation Considerations:

1. Gates are available with fabricated side plates or for installation in a rectangular concrete section.

IRRIGATION DIVERSION STRUCTURE LIFT PANEL CHECK

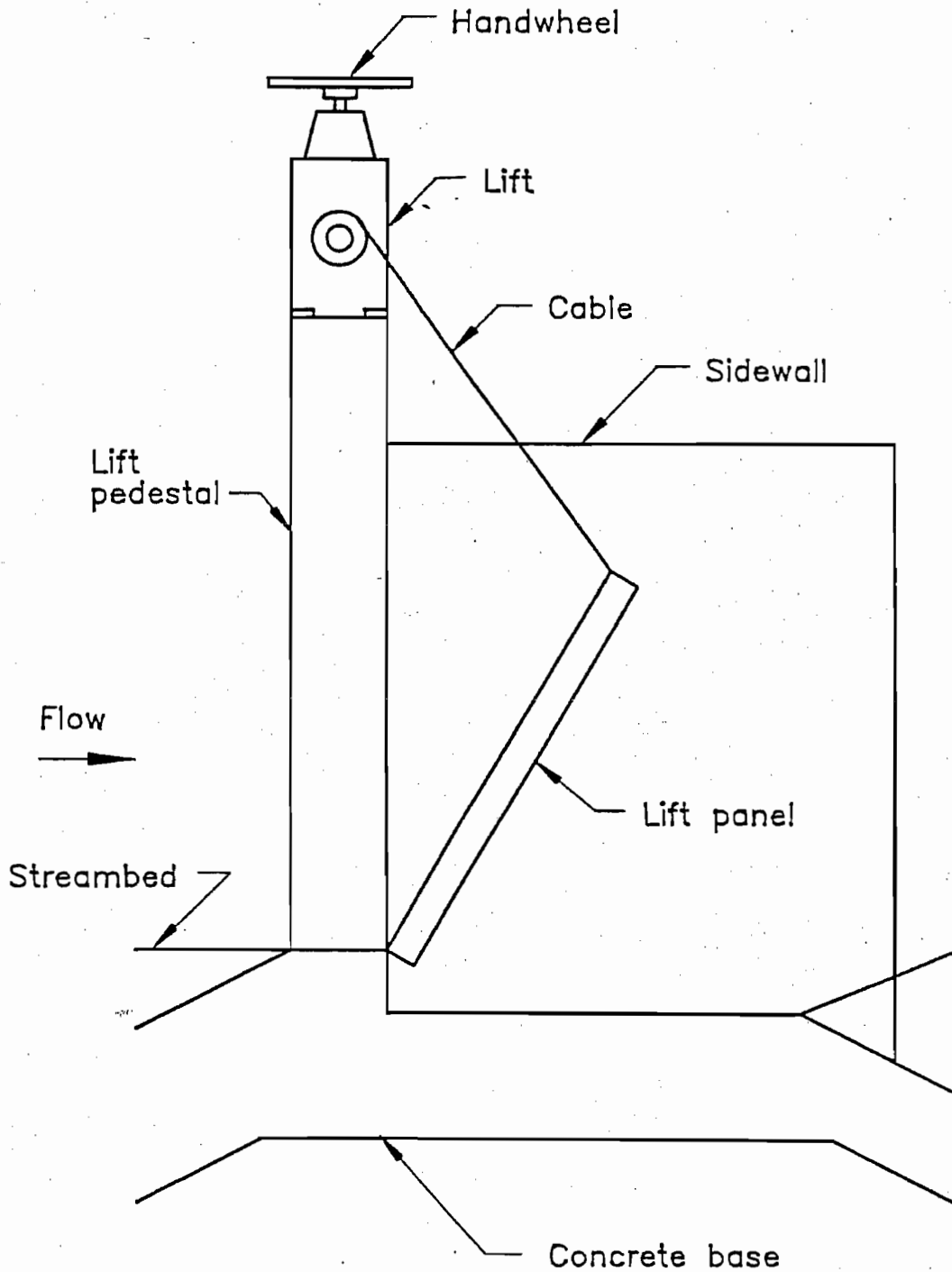

FIGURE 4

IRRIGATION DIVERSION STRUCTURE
DESIGN CRITERIA AND SPECIFICATIONS
PREFABRICATED BEAM CHECK

Description:

The prefabricated beam check is constructed of a single or a series of beams of the height required to divert the irrigation flow. See figure 5. This beam may be wood, reinforced concrete, or steel. For a relatively long span a reinforced concrete T beam would probably be the most economical. Prestressed beams may be used for extremely long spans

References:

1. Soil Conservation Service, National Engineering Handbook Section 5 Hydraulics, Soil Conservation Service, Washington D.C.
2. Soil Conservation Service, National Engineering Handbook Section 6 Structural Design, Soil Conservation Service, Washington D.C.
3. Soil Conservation Service, Engineering Design Standards Far West States, West National Technical Center, Portland, Oregon, 1970.

Costs:

The approximate cost for a 20 foot wide check with a 3 foot head is \$500 to \$1000.

Installation Considerations:

1. A backhoe or small crane will probably be required to install the check.
2. Abutment blocks will be required to receive the ends of the beam and supply support.

IRRIGATION DIVERSION STRUCTURE FABRICATED BEAM CHECK

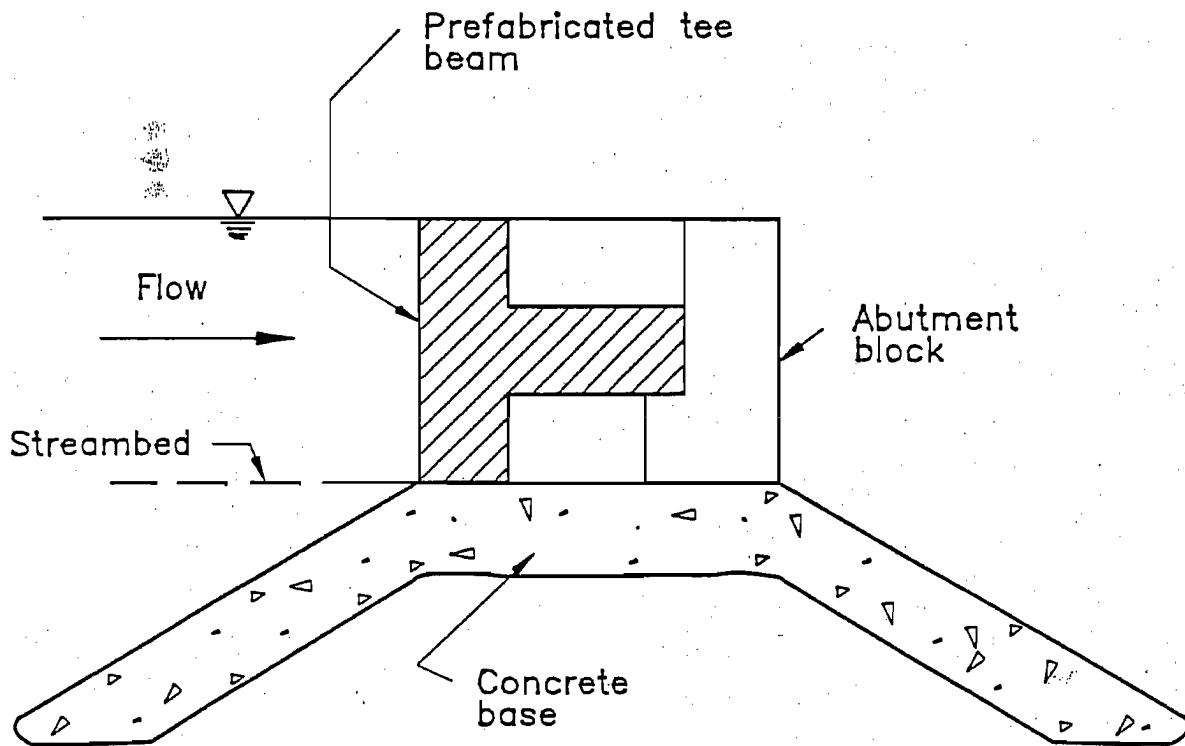

FIGURE 5

IRRIGATION DIVERSION STRUCTURE
DESIGN CRITERIA AND SPECIFICATIONS
SWINGING PIPE CHECK

Description:

A swinging pipe check is constructed using 6 inch diameter steel pipe stacked horizontally across the water course. See figure 6. Each pipe is individually hinged on one side to provide for checking the water in increments and to reduce the force needed to remove a pipe under pressure. Channels with widths up to 25 feet may be checked without interfering supports. This clear opening eliminates problems with trash and the need to construct walkways over the channel. Cables are required to be attached to the individual pipes when there is a need to regulate the head while water is flowing over the check.

References:

1. Soil Conservation Service, National Engineering Handbook Section 5 Hydraulics, Soil Conservation Service, Washington D.C.
2. Soil Conservation Service, National Engineering Handbook Section 6 Structural Design, Soil Conservation Service, Washington D.C.

Costs:

The approximate unit cost for swinging pipe check is \$70 to \$150 per foot.

Installation Considerations:

1. A simple foundation (usually concrete) is required.

IRRIGATION DIVERSION STRUCTURE SWINGING PIPE CHECK

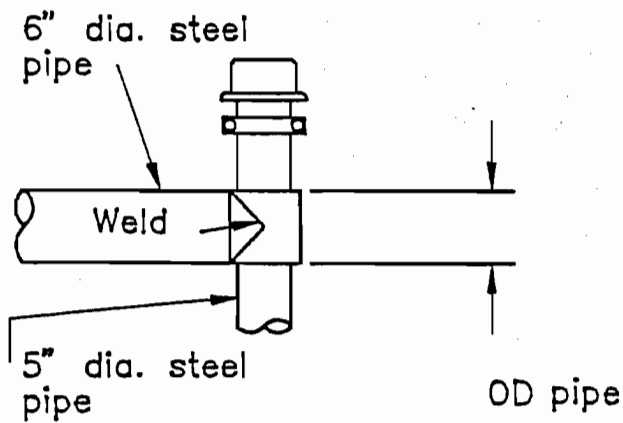
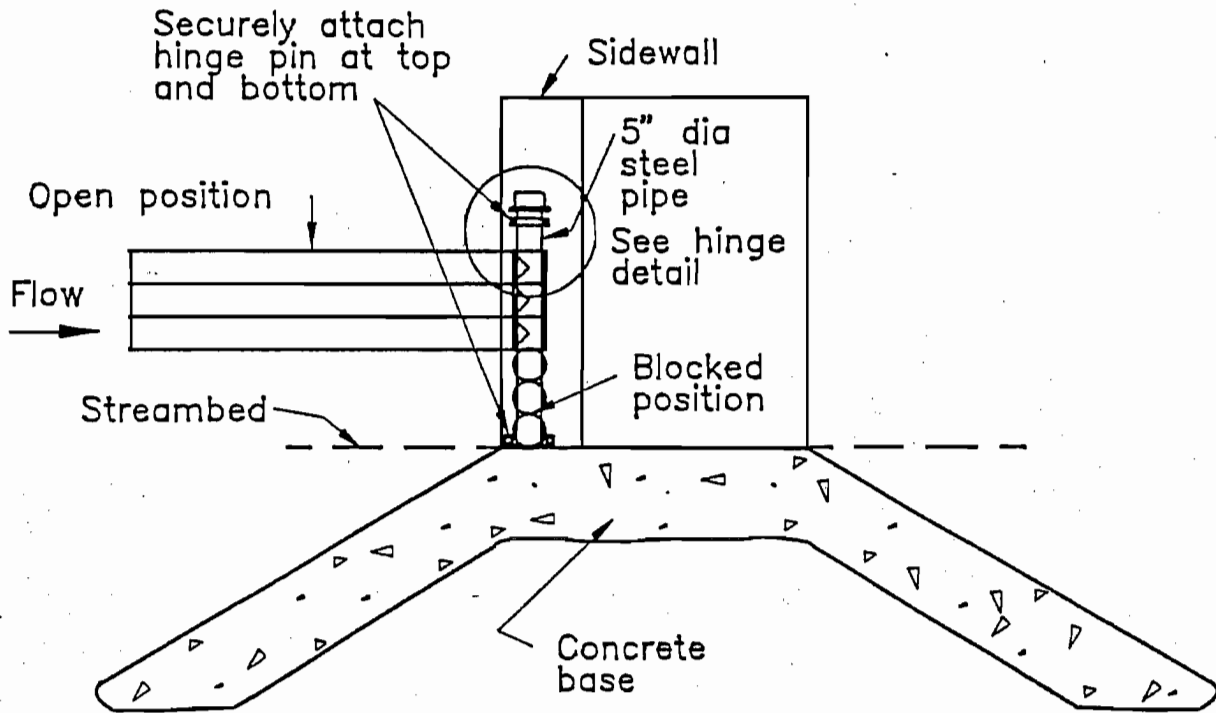

HINGE DETAIL

FIGURE 6

IRRIGATION DIVERSION STRUCTURE
DESIGN CRITERIA AND SPECIFICATIONS
WIRE FENCING AND GEOSYNTHETIC CHECK

Description:

A wire fencing and geosynthetic check consists of fence posts, fencing, and geosynthetic fabric to construct the required headwall cutoff, and apron for an irrigation diversion dam. Figure 7 is a typical cross section for a fence structure with a height of 18 inches or less. Figure 8 is a typical cross section for a fence structure with a height of 18 to 30 inches. Standard "T" steel and/or wood posts may be used. The posts should be cut off a few inches above the planned fence height to minimize debris snags. Numerous erosion control netting, fabric, and silt fence products are commercially available that may be used in conjunction with the wire mesh fencing along the headwall and apron of the structure.

References:

1. Soil Conservation Service, National Engineering Handbook Section 5 Hydraulics, Soil Conservation Service, Washington D.C.
2. Soil Conservation Service, National Engineering Handbook Section 6 Structural Design, Soil Conservation Service, Washington D.C.
3. Designing with Geosynthetics, Robert M. Koerner, Ph.D., P.E., Prentice Hall, Englewood Cliffs, New Jersey 07632
4. Industrial Fabrics Association International, Geotechnical Fabrics Report, Industrial Fabrics Association International, 345 Cedar St., St. Paul, Minnesota 55101
5. American Society of Agricultural Engineers, Engineering Practice: EP250.2, Specifications for Farm Fence Construction, American Society of Agricultural Engineers, 2950 Niles Road, St. Joseph, Michigan.

Costs:

The approximate unit cost for wire fencing and geosynthetic check is \$10 to \$25 per foot.

Installation Considerations:

1. Minor shaping of the channel bottom or bank, both upstream and downstream of the headwall, may be required

to ensure that netting and fencing maintain contact with the surface of the ground.

IRRIGATION DIVERSION STRUCTURE WIRE FENCING AND GEOSYNTHETIC CHECK

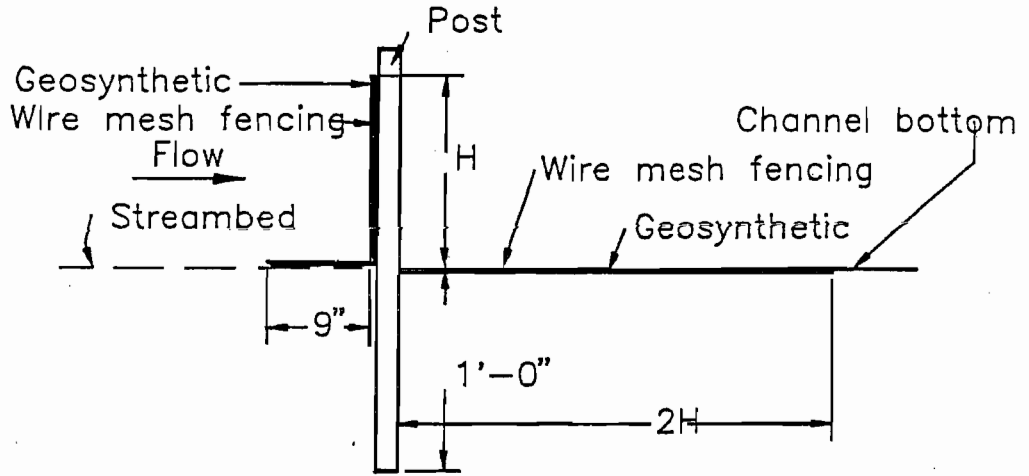
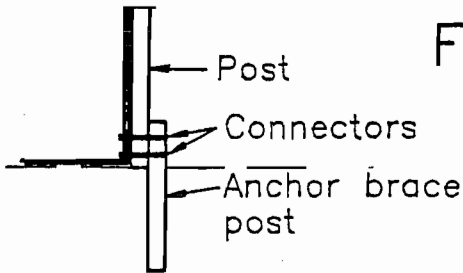

FIGURE 7



TEMPORARY CHECK
CONNECTION

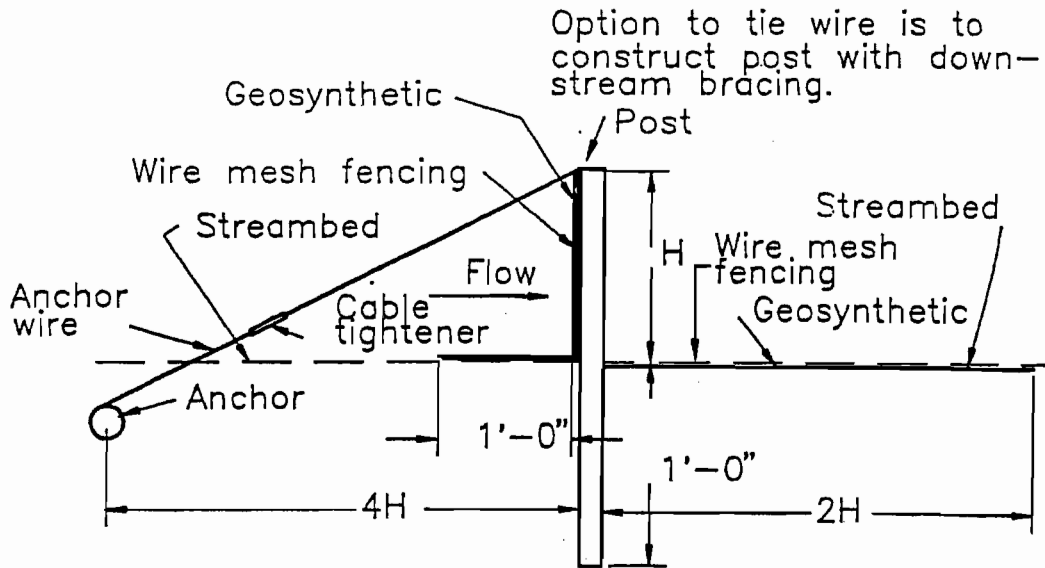

FIGURE 8